

TILLAMOOK COUNTY AND K & B QUALITY EXCAVATING, LLC
PREVAILING WAGE RATE CONTRACT FOR CONSTRUCTION
FAIRVIEW ROAD HUGHEY CREEK CULVERT CONSTRUCTION PROJECT

This contract is entered into, in duplicate, by and between TILLAMOOK COUNTY, a political subdivision of the State of Oregon, hereafter called "county", and K & B QUALITY EXCAVATING, LLC, hereafter called "contractor", for the project entitled "FAIRVIEW ROAD HUGHEY CREEK CULVERT CONSTRUCTION PROJECT", hereinafter called "contract". The mutual promises of each are given in exchange and as consideration for, the promises of the other.

Contractor and county mutually covenant and agree as follows:

1. The GRAND TOTAL PRICE for services provided by contractor to county shall be in the amount quoted in the "Bid Form" which is the cost to county of One Hundred Twenty-Nine Thousand Four Hundred Eighty and 15/100 Dollars (\$129,480.15), unless otherwise adjusted in accordance with the terms of this contract.
2. The time of completion for this project is September 30, 2023.
3. Contract documents:
 - 3.1 The following "contract documents" are attached and are specifically incorporated herein in their entirety by reference:
 - 3.1.1. This Contract;
 - 3.1.2. General Conditions;
 - 3.1.3. Public Contract Provisions;
 - 3.1.4. Bid Form;
 - 3.1.5. Invitation to Bid; and
 - 3.1.6. Performance Bond.
 - 3.2 The following contract documents are specifically incorporated herein by reference in their entirety:
 - 3.2.1. Oregon Prevailing Wage Rate Bulletin dated January 5, 2023.

Contractor agrees as follows:

4. In consideration of the sums to be paid by county in the manner and at the times provided and in consideration of the other covenants and agreements contained herein, contractor agrees to perform and complete the work herein described. This contract shall be binding upon the contractor's heirs, executors, administrators, successors and assigns.
5. Contractor shall faithfully complete and perform all of the obligations of the Contract and in particular, shall promptly, as due, make payment of all just debts, dues, demands and obligations incurred in the performance of said contract; and shall not permit any lien or claim to be filed or prosecuted against the county, its agents or employees.

TILLAMOOK COUNTY AND K & B QUALITY EXCAVATING, LLC
PREVAILING WAGE RATE CONTRACT FOR CONSTRUCTION
FAIRVIEW ROAD HUGHEY CREEK CULVERT CONSTRUCTION PROJECT

6. Contractor shall not permit any lien or claim to be filed or prosecuted against the county and shall hold the county harmless for any liens, claims, damages or other liabilities of the contractor related to the performance of this contract. Contractor shall indemnify and save harmless the county from any claims, costs, damages or expenses of any kind, including attorney's fees and other costs and expenses of litigation for personal or property damage to contractor or to third parties arising out of contractor's performance of the duties required by this contract.

County agrees as follows:

7. In consideration of the faithful performance of all of the obligations, general and special, herein set out and in consideration of the faithful performance of the work as set forth in the contract documents in accordance with the county and to its satisfaction, the county agrees to pay to the contractor the amount earned and to make such payments in the manner and at the times provided in the applicable specifications and schedule of contract prices.

The parties mutually agree as follows:

8. Miscellaneous
 - 8.1 Integration
This contract supersedes all prior oral or written agreements between contractor and county regarding this project. It represents the entire agreement between the parties.
 - 8.2 Savings
Should any clause or section of this contract be declared by a court to be void or voidable, the remainder of this contract shall remain in full force and effect.
 - 8.3 Waiver; Modification
Failure to enforce any provision of this contract does not constitute a continuing waiver of that provision, any other provision or of the entire contract. The rights and duties under this contract shall not be modified, delegated, transferred or assigned, except upon the written-signed consent of both parties.
 - 8.4 Jurisdiction; Law
This contract is executed in the State of Oregon and is subject at all times to Tillamook County Ordinances and Oregon law and jurisdiction. Venue shall be in Tillamook County, unless otherwise agreed by the parties.

TILLAMOOK COUNTY AND K & B QUALITY EXCAVATING, LLC
PREVAILING WAGE RATE CONTRACT FOR CONSTRUCTION
FAIRVIEW ROAD HUGHEY CREEK CULVERT CONSTRUCTION PROJECT

8.5 Attorney Fees

Attorney fees, costs and disbursements necessary to enforce this contract through mediation, arbitration and/or litigation, including appeals, shall be awarded to the prevailing party, unless otherwise specified herein or agreed.

8.6 Notices

Any notice required or permitted under this contract shall be in writing and deemed given when:

8.6.1. Actually delivered, or

8.6.2. Three (3) days after deposit in the United States Mail, certified, postage prepared, addressed to the other party at their last known address.

8.7 Breach

Contractor agrees to immediately notify county of any potential unauthorized breach, use or disclosure of data or information, and to take all actions reasonably necessary to prevent further unauthorized use or disclosure thereof.

ACKNOWLEDGEMENT: EACH PARTY REPRESENTS TO THE OTHER BY THEIR SIGNATURES BELOW THAT EACH HAS READ, UNDERSTANDS AND AGREES TO ALL COVENANTS, TERMS AND CONDITIONS OF THIS CONTRACT. EACH PARTY REPRESENTS BY THEIR SIGNATURES BELOW TO HAVE THE ACTUAL AND/OR APPARENT AUTHORITY TO BIND THEIR RESPECTIVE PARTY IN CONTRACT.

Approved as to form this 27th day of July, 2023.

Contract Officer

//

//

//

//

TILLAMOOK COUNTY AND K & B QUALITY EXCAVATING, LLC
PREVAILING WAGE RATE CONTRACT FOR CONSTRUCTION
FAIRVIEW ROAD HUGHEY CREEK CULVERT CONSTRUCTION PROJECT

Dated this ____ day of _____, 2023.

CONTRACTOR: K & B QUALITY EXCAVATING, LLC

Kevin Rariden
360 Burnt Woods Trail
Blodgett, Oregon 97326
541-602-9166
tntconsulting14@gmail.com

Dated this ____ day of _____, 2023.

THE BOARD OF COMMISSIONERS
FOR TILLAMOOK COUNTY, OREGON

Aye Nay Abstain/Absent

Erin D. Skaar, Chair

___ ___ ___/___

Mary Faith Bell, Vice-Chair

___ ___ ___/___

David Yamamoto, Commissioner

___ ___ ___/___

ATTEST: Tassi O'Neil,
County Clerk

APPROVED AS TO FORM:

By: _____
Special Deputy

William K. Sargent,
County Counsel

TILLAMOOK COUNTY AND K & B QUALITY EXCAVATING, LLC
PREVAILING WAGE RATE CONTRACT FOR CONSTRUCTION
FAIRVIEW ROAD HUGHEY CREEK CULVERT CONSTRUCTION PROJECT

GENERAL CONDITIONS

1. CONFLICTS

In case of conflict between the general conditions and the project specifications (also known as "special provisions"), the project specifications shall govern.

2. START OF WORK

2.1 The contractor is not authorized to go onto the property on which the work is to be done, nor move materials, equipment or workers onto that property, nor to start on-site work until the contract with the county is signed, the county sends the contractor written notice to proceed with the work and the contractor has filed the public works bonds required in the invitation to bid.

2.2 The contractor shall coordinate with the county's designated representative in accordance with the project specifications.

3. TIME OF COMPLETION

The contract completion date for this project shall be September 30, 2023.

4. DESCRIPTION OF WORK (also known as project special provisions or specifications)

Contractor shall execute details of the contract in accordance with the attached project specifications.

5. LIQUIDATED DAMAGES

If the contractor fails to have all the work completed by the contract completion date, the contractor shall be assessed liquidated damages. The actual cost to the public for the failure of the contractor to complete the work on time will be difficult and/or impractical to determine. Therefore, it is agreed the contractor pay the county, not as a penalty but as liquidated damages, Four Hundred Dollars (\$400) per calendar day for each day after the contract completion date until all of the contract work is completed.

6. PROGRESS PAYMENTS

6.1 The contractor shall receive progress payments for the work completed at the end of each month; less a five percent (5%) retainage. Additional retainage of twenty-five percent (25%) of amounts earned will be withheld and released according to ORS 279C.845 when the contractor fails to file the certified statements required in ORS 279C.845.

TILLAMOOK COUNTY AND K & B QUALITY EXCAVATING, LLC
PREVAILING WAGE RATE CONTRACT FOR CONSTRUCTION
FAIRVIEW ROAD HUGHEY CREEK CULVERT CONSTRUCTION PROJECT

- 6.2 Progress payments will be based upon estimates of the work completed, that are approved by the county's designated representative, as of the end of the month.
- 6.3 Progress payments will include payment for materials delivered to the site, but not incorporated into the work. To receive progress payments for these materials the contractor shall provide the county with statements or invoices by the supplier stating the type, quantity and cost of the materials. Progress payments shall not be considered acceptance or approval of any work or waiver of any defects therein.
- 6.4 Contractor requests for progress payments shall be in a format following the bid line items to facilitate project cost tracking.
- 6.5 The payments will be made within thirty (30) days after the receipt of the contractor's invoice. Monthly invoices shall be submitted simultaneously to:

Tillamook County Public Works
503 Marolf Loop
Tillamook, Oregon 97141
pwinvoices@co.tillamook.or.us

7. PERFORMANCE BOND

The successful bidder will be required to furnish a Performance and Labor & Material Bond in the amount of one hundred percent (100%) of the contract as security for the faithful performance of this contract and as security for payment of all persons performing labor under this contract and furnishing materials in connection with this contract.

8. PUBLIC WORKS BOND

Before starting work, the contractor and sub-contractors shall each file with the Construction Contractors Board and maintain in full force and effect, a separate public works bond, in the amount of Thirty Thousand Dollars (\$30,000) unless otherwise exempt, under ORS 279C.836(7) or (8). The contractor shall verify sub-contractors have filed a public works bond before the sub-contractor begins work.

9. LIABILITY INSURANCE

The contractor shall obtain and maintain such public liability and damage insurance as will protect the contractor for any and all claims for damage or

TILLAMOOK COUNTY AND K & B QUALITY EXCAVATING, LLC
PREVAILING WAGE RATE CONTRACT FOR CONSTRUCTION
FAIRVIEW ROAD HUGHEY CREEK CULVERT CONSTRUCTION PROJECT

personal injury, including death, which may arise from the operations under the contract. Such insurance shall provide coverage for not less than the following:

Property Damage:	\$1,000,000 (one claimant)
	\$2,000,000 (all claimants)
Personal Injury or Death:	\$2,000,000 (one claimant)
	\$2,000,000 (all claimants)

Such insurance shall be on an occurrence basis only and be evidenced by a certificate of insurance provided to the county, indicating coverages, limits and effective dates, by an insurance company licensed to do business in the State of Oregon. An endorsement shall be issued by the company showing the county as an additional insured on all coverages, excepting medical/professional malpractice insurance. The endorsement shall also contain a notice of cancellation provision.

10. RECYCLING

- 10.1 If the project proposal includes demolition, the contractor is required to salvage or recycle construction and demolition debris, if feasible and cost-effective in accordance with ORS 279C.510(1).
- 10.2 If the project proposal includes lawn and landscape maintenance, the contractor is required to compost or mulch yard waste material at an approved site, if feasible and cost effective.

11. WORK BY OTHERS

County's representative will track contractor progress. Details of county's representative involvement with the contractor are outlined in the project specifications.

12. WARRANTY

- 12.1 Contractor shall warrant all project work, labor and materials performed in accordance with these contract documents for one (1) year after the date of substantial completion of the work subject to the following, if applicable:
- 12.1.1. Terms of an applicable special warranty required by the contract documents, or
- 12.1.2. Extension of start of the one (1) year warranty time period based upon completion of portions of outstanding work to be completed after notice of substantial completion. The specific details of what comprises substantial completion shall be prepared and submitted by the contractor to the owner for approval/concurrence.

TILLAMOOK COUNTY AND K & B QUALITY EXCAVATING, LLC
PREVAILING WAGE RATE CONTRACT FOR CONSTRUCTION
FAIRVIEW ROAD HUGHEY CREEK CULVERT CONSTRUCTION PROJECT

13. CORRECTION OF WORK

For any portion of project work found not to be in accordance with the contract documents, the contractor shall correct it promptly after receipt of written notice from the owner to do so unless the owner has previously given the contractor a written acceptance of such condition. Owner will give such notice promptly after discovery of the condition. The one (1) year warranty on such corrected work will begin when the correction has been made.

14. SCHEDULES & INSPECTIONS

14.1 All work is to be inspected during construction by the county's representative.

14.2 Schedules and inspections coordination with the county's representative shall be in accordance with the project specifications.

15. PERMITS

15.1 The contractor shall obtain and pay for all permits and connection fees pertaining to the construction of this project as required with the following exception:

15.1.1. The county has obtained the required environmental clearance permit for the project construction as outlined in the plans.

15.2 The contractor shall pay all other permit fees including utility connection fees and monthly invoices related to utilities usage for project work. See project specifications for more information.

15.3 All contractor paid permit and connection fees shall be incorporated into the Bid Form Part I Quote (except as noted above) under the general requirements bid item.

END OF GENERAL CONDITIONS

TILLAMOOK COUNTY AND K & B QUALITY EXCAVATING, LLC
PREVAILING WAGE RATE CONTRACT FOR CONSTRUCTION
FAIRVIEW ROAD HUGHEY CREEK CULVERT CONSTRUCTION PROJECT

PUBLIC CONTRACT PROVISIONS

1. Contractor shall pay promptly, as due, all persons supplying labor or materials for the prosecution of the work provided for in the contract, and shall be responsible for such payment of all persons supplying such labor or material to any sub-contractor.
2. The contractor shall include in each sub-contract for property or services entered into by the contractor and a first-tier sub-contractor, including a material supplier, for the purpose of performing this contract:
 - 2.1 A payment clause that obligates the contractor to pay the first-tier sub-contractor for satisfactory performance under its sub-contract within ten (10) days out of such amounts as are paid to the contractor by the county under this contract; and
 - 2.2 An interest penalty clause that obligates the contractor, if payment is not made within thirty (30) days after receipt of payment from the county, to pay to the first-tier sub-contractor an interest penalty on amounts due in the case of each payment not made in accordance with the payment clause included in the sub-contract pursuant to ORS 279C.580. A contractor or first-tier sub-contractor shall not be obligated to pay an interest penalty if the only reason that the contractor or first-tier sub-contractor did not make payment when payment was due is that the contractor or first-tier sub-contractor did not receive payment from the county or contractor when payment was due. The interest penalty shall be:
 - 2.2.1. For the period beginning on the day after the required payment date and ending on the date on which payment of the amount due is made; and
 - 2.2.2. Computed at the rate specified in ORS 279C.515(2).
 - 2.3 A provision requiring the sub-contractor to have a public works bond filed with the Construction Contractors' Board before starting work on the project, unless exempt.
 - 2.4 A provision requiring that the workers shall be paid not less than the specified minimum hourly rate of wage.
3. The contractor shall include in each of its sub-contracts, for the purpose of performance of such contract condition, a provision requiring the first-tier sub-contractor to include a payment clause and an interest penalty clause conforming to the standards of ORS 279C.580(4) in each of its sub-contracts and to require each of its sub-contractors to include such clauses in their sub-contracts with each lower-tier sub-contractor or supplier.
4. If the contractor or a sub-contractor fails, neglects or refuses to make payment to a person furnishing labor or materials in connection with a public contract, the

TILLAMOOK COUNTY AND K & B QUALITY EXCAVATING, LLC
PREVAILING WAGE RATE CONTRACT FOR CONSTRUCTION
FAIRVIEW ROAD HUGHEY CREEK CULVERT CONSTRUCTION PROJECT

person may file a complaint with the Construction Contractors' Board, unless payment is subject to a good faith dispute as defined in ORS 279C.580.

5. A dispute between the contractor and a sub-contractor relating to the amount of entitlement of a sub-contractor to a payment or a late payment interest penalty under a clause including in the sub-contract, pursuant to this section, does not constitute a dispute to which the county is a party. The county shall not be included as a party in any administrative or judicial proceedings involving such a dispute.
6. The rights, duties and obligations of the contractor, sub-contractors and county with respect to relations with the contractor shall be as set forth in ORS 279C.580 incorporated herein by reference.
7. Contractor shall promptly pay all contributions or amounts due the Industrial Accident Fund from such contractor or sub-contractor incurred in the performance of the contract, and shall be responsible that all sums due the State Unemployment Compensation Fund from contractor or any sub-contractor in connection with the performance of the contract shall promptly be paid.
8. Contractor shall not permit any lien or claim to be filed or prosecuted against the county on account of any labor or materials furnished and agrees to assume responsibility for satisfaction of any such lien so filed or prosecuted.
9. Contractor and any sub-contractor shall pay to the Department of Revenue all sums withheld from employees pursuant to ORS 316.167.
10. Contractor shall demonstrate to the county, within ten (10) days of receiving a notice of award, that contractor has an employee drug testing program pursuant to ORS 279C.505(2).
11. If contractor fails, neglects or refuses to make prompt payment of any claim for labor or materials furnished to the contractor or a sub-contractor by any person in connection with the contract as such claim becomes due, the owner may pay such claim to the persons furnishing the labor or materials and charge the amount of payment against funds due or to become due contractor by reason of the contract. The payment of a claim in the manner authorized hereby shall not relieve the contractor or contractor's surety from contractor's or surety's obligation with respect to any unpaid claim. If the owner is unable to determine the validity of any claim for labor or materials furnished, the owner may withhold from any current payment due contractor an amount equal to said claim until its validity is determined and the claim, if valid, is paid.
12. If the contractor or a first-tier sub-contractor fails, neglects, or refuses to make payment to a person furnishing labor or materials in connection with the public contract for a public improvement within thirty (30) days after receipt of payment

TILLAMOOK COUNTY AND K & B QUALITY EXCAVATING, LLC
PREVAILING WAGE RATE CONTRACT FOR CONSTRUCTION
FAIRVIEW ROAD HUGHEY CREEK CULVERT CONSTRUCTION PROJECT

from the public contracting agency or contractor, the contractor or first-tier sub-contractor shall owe the person the amount due plus interest charges commencing at the end of the ten (10) day period that payment is due under ORS 279C.580 and ending upon final payment, unless payment is subject to a good faith dispute as defined in ORS 279C.580. The rate of interest charged to contractor or first-tier sub-contractor on the amount due is nine percent (9%) annum. The amount of interest may not be waived.

13. Contractor shall promptly, as due, make payment to any person, co-partnership, association, or corporation furnishing medical surgical and hospital care or other needed care and attention, incident to sickness or injury, to employees of such contractor, of all sums which the contractor agrees to pay for such services and all monies and sums which the contractor collected or deducted from the wages of employees pursuant to any law, contract or agreement for the purpose of providing or paying for such service.
14. Contractor shall employ no person for more than ten (10) hours in any one (1) day, or forty (40) hours in any one (1) week, except in cases of necessity, emergency, or where public policy absolutely requires it, and in such cases, contractor shall pay the employee at least time and one-half (1 and 1/2) pay for all overtime in excess of eight (8) hours a day or forty (40) hours in any one (1) week when the work is five (5) consecutive days, Monday through Friday; or for all overtime in excess of ten (10) hours a day or forty (40) hours in any one (1) week when the work week is four (4) consecutive days, Monday through Friday, and for all work performed on Saturday and on any legal holidays as specified in ORS 279C.540.
15. The contractor must give notice to employees who work on this contract in writing, either at the time of hire or before commencement of work on the contract, or by posting a notice in a location frequented by employees, of the number of hours per day and the days per week that the employees may be required to work.
16. This is a contract subject to prevailing wage rates. Contractor shall comply with the provisions of ORS 279C.840 to 279C.870. Workers shall be paid not less than the specified minimum hourly rate of wage in accordance with ORS 279C.838. Every sub-contract shall contain a provision imposing the requirements of this program.
17. All employers including contractor, that employ subject workers who work under this contract in the State of Oregon shall comply with ORS 656.017 and provide the required Workers' Compensation coverage, unless such employers are exempt under ORS 656.126. Contractor shall ensure that each of its sub-contractors complies with these requirements.

TILLAMOOK COUNTY AND K & B QUALITY EXCAVATING, LLC
PREVAILING WAGE RATE CONTRACT FOR CONSTRUCTION
FAIRVIEW ROAD HUGHEY CREEK CULVERT CONSTRUCTION PROJECT

18. All sums due the State Unemployment Compensation Fund from the contractor or any sub-contractor in connection with the performance of the contract shall be promptly paid.
19. The contract may be cancelled at the election of owner for any willful failure on the part of contractor to faithfully perform the contract according to its terms.
20. Contractor must give notice to employees, in writing, that they cannot be discharged, demoted, or otherwise discriminated against as a reprisal for disclosing information that the employee reasonably believes is evidence of gross mismanagement of a Federal contract or grant, a gross waste of Federal funds, an abuse of authority relating to a Federal contract or grant, a substantial and specific danger to public health or safety, or a violation of a law, rule, or regulation related to a Federal contract or grant.
21. Various federal, state and local agencies have enacted ordinances or regulations dealing with the prevention of environmental pollution and the preservation of natural resources that affect the performance of this contract. These agencies include, but are not limited to:

FEDERAL AGENCIES:

Agriculture, Department of
Forest Service
Natural Resources Conservation Service
Defense, Department of
Army Corps of Engineers
Environmental Protection Agency
Interior, Department of
US Fish and Wildlife Service
Bureau of Land Management
Bureau of Indian Affairs
Bureau of Reclamation
Labor, Department of
Occupational Safety and Health Administration

STATE AGENCIES:

Agriculture, Department of
Environmental Quality, Department of
Fish and Wildlife, Department of
Forestry, Department of
Land Conservation and Development Commission
Soil and Water Conservation Commission

LOCAL AGENCIES:

City Council
County Court

TILLAMOOK COUNTY AND K & B QUALITY EXCAVATING, LLC
PREVAILING WAGE RATE CONTRACT FOR CONSTRUCTION
FAIRVIEW ROAD HUGHEY CREEK CULVERT CONSTRUCTION PROJECT

County Commissioners, Board of
Port Districts
County Service Districts
Sanitary Districts
Water Districts
Fire Protection Districts

Pursuant to ORS 279C.525(1). If the successful bidder awarded the project is delayed or must undertake additional work by reason of existing regulations or ordinances of agencies not cited in the public contract or due to the enactment or new or the amendment of existing statutes, ordinance or regulations relating to the prevention of environmental pollution and the preservation of natural resources occurring after the submission of the successful bid, the public contracting agency may:

- 21.1 Terminate the contract;
- 21.2 Complete the work itself;
- 21.3 Use non-agency forces already under contract with the public contracting agency;
- 21.4 Require that the underlying property owner be responsible for cleanup;
- 21.5 Go out to bid for a new contractor to provide the necessary services under the competitive bid requirements of ORS 279C.335; or
- 21.6 Issue the successful bidder a change order setting forth the additional work that must be undertaken.

END OF PUBLIC CONTRACT PROVISIONS

TILLAMOOK COUNTY
 CALL FOR BIDS – PREVAILING WAGE RATE CONTRACT FOR CONSTRUCTION
 FAIRVIEW ROAD HUGHEY CREEK CULVERT CONSTRUCTION PROJECT

SECTION 00030
 BID DOCUMENTS
 PART I (BID FORM)

Bid Closing: 10:00 a.m. on Thursday, July 20, 2023
 Bid Form Part I due at bid closing
 Bid Form Part II due not later than 12:00 p.m. on Thursday, July 20, 2023 (i.e. within two (2) working hours of the above bid due date/time).

Submission location indicated on the Part II Bid Form.

Bid Opening: 10:05 a.m. on Thursday, July 20, 2023.

Submitted to: Tillamook County Public Work's Office, Attn: Nicole Baldwin
 503 Marolf Loop, Tillamook, Oregon 97141

ITEM NO.	ITEM DESCRIPTION	QTY	UNIT	UNIT PRICE	TOTAL PRICE
1	MOBILIZATION	1	LS	26,550. ⁰⁰	26,550. ⁰⁰
2	STREAM DIVERSION	1	LS	12,500. ⁰⁰	12,500. ⁰⁰
3	STREAM BED EXCAVATION - RESTORATION	135	CY	123. ⁰⁷	16,614. ⁴⁵
4	ASSEMBLE & INSTALL ALSP CULVERT	1	LS	16,590. ⁰⁰	16,590. ⁰⁰
5	GRANULAR BACKFILL - CULVERT & ROAD BED	725	CY	29. ⁰⁵	21,061. ²⁵
6	SHOULDER ROCK PLACED	25	CY	29. ⁰⁵	726. ²⁵
7	GEOTEXTILE FABRICS	100	SQ YD	1. ⁵⁰	150. ⁰⁰
8	LEVEL 3, 1/2 INCH ACP MIX	60	TON	160. ⁰⁰	9,600. ⁰⁰
9	LONGITUDINAL PAVEMENT MARKINGS	340	LF	1. ⁵³	520. ²⁰
10	GUARD RAIL END PIECES, TYPE B	2	EA	125. ⁰⁰	250. ⁰⁰
11	ENERGY ABSORBING END TREATMENT	2	EA	4,350. ⁰⁰	8,700. ⁰⁰
12	MIDWEST GUARD RAIL	240	LF	42. ⁰⁰	10,080. ⁰⁰
13	REVTMENT BOULDERS & KEY ROCKS PLACED	60	TON	102. ³⁰	6,138. ⁰⁰

GRAND TOTAL \$ 129,480.¹⁵

GRAND TOTAL IN WORDS One Hundred Twenty nine Thousand Four Hundred Eighty Dollars & ¹⁵/₁₀₀

K.R. Bid Form (Part I) not complete without all 2 pages.
 Initials (same person signing page 2 of this Bid Form)

TILLAMOOK COUNTY
CALL FOR BIDS – PREVAILING WAGE RATE CONTRACT FOR CONSTRUCTION
FAIRVIEW ROAD HUGHEY CREEK CULVERT CONSTRUCTION PROJECT

I have examined copies of all project bid documents and the following addenda:

DATE: ^{17 KB} July 20, 2023
DATE: _____
DATE: _____

ADDENDUM # ^{1 KB} ~~0~~ Addenda Received
ADDENDUM # _____
ADDENDUM # _____

I certify that I will comply with the Prevailing Wage Laws as required in ORS 279C.800 to 279C.870 or 40 USC 276a.

I certify that I will comply with the Oregon Workers' Compensation Laws as required in ORS 656.017.

I certify that this company is a resident bidder, as defined by ORS 279A.120, of the State of Oregon.

I certify that this company has a valid certificate of registration with the Oregon Construction Contractors' Board. Registration No. 202260.

I certify that I have not discriminated against minority, women or emerging small business enterprises in obtaining any required sub-contracts.

I certify that all sub-contractors performing work described in ORS 701.005(2) (i.e. construction work) will be registered with the Construction Contractors Board or licensed by the State Landscape Contractors Board in accordance with ORS 701.035 to 701.055 before the sub-contractors commence work under this contract.

I certify, under penalty of perjury, that I have complied with the tax laws of the State of Oregon or a political subdivision of the State of Oregon.

QUOTE BY: 
(Signature)

K & B Quality Excavating, LLC
(Company)

360 Burnt Woods Trail, Blodgett, OR 97326
(Address, City, State, Zip)

(541) 602-9166
(Phone Number)

* Quote may also be called "bid schedule" elsewhere in project documents.

Bid Form (Part I) not complete without all 2 pages.

KB Initials (same person signing page 2 of this Bid Form)

TILLAMOOK COUNTY
 CALL FOR BIDS – PREVAILING WAGE RATE CONTRACT FOR CONSTRUCTION
 FAIRVIEW ROAD HUGHEY CREEK CULVERT CONSTRUCTION PROJECT

SECTION 00040
 BID DOCUMENTS
 PART II (FIRST-TIER SUB-CONTRACTOR DISCLOSURE FORM)

In accordance with OAR 137-049-0360:

PROJECT NAME: FAIRVIEW ROAD HUGHEY CREEK CULVERT CONSTRUCTION PROJECT

BID CLOSING: 10:00 a.m. on Thursday, July 20, 2023

DISCLOSURE FORM SUBMISSION DEADLINE: 12:00 p.m. on Thursday, July 20, 2023

This form must be submitted not later than the DISCLOSURE FORM SUBMISSION DEADLINE stated above.

List below the name and category of work that each sub-contractor will be performing. List of all sub-contractors that will be furnishing labor or labor and materials that are required to be disclosed. Enter "NONE" if there are no sub-contractors that need to be disclosed. (IF NEEDED, ATTACH ADDITIONAL SHEETS)

NAME	CATEGORY OF WORK	VALUE OF SUB-CONTRACT
Dirt & Aggregate Interchange	Guardrail K.R.	\$28,000.00 K.R.
K.B. K&B Construction, LLC	Guardrail	23,330.00

The above listed first-tier sub-contractor(s) are providing labor or labor and materials where a dollar value would be equal to or greater than:

- Five percent (5%) of the total contract price, but at least Fifteen Thousand Dollars (\$15,000) (including all alternates). If the dollar value is less than Fifteen Thousand Dollars (\$15,000), do not list the sub-contractor above, or
- Three Hundred Fifty Thousand Dollars (\$350,000) regardless of the percentage of the total contract price.

Bids which are submitted by bid closing, but for which the separate and sealed disclosure submittal has not been submitted by the specified deadline, are not responsive and shall not be considered for contract award.

Form Submitted by: Kevin Rariden, Managing Member / Owner of K & B Quality Excavating, LLC
 (Bidder Name)

Bidder Signature (same as Part I Bid Form): 

TILLAMOOK COUNTY
CALL FOR BIDS – PREVAILING WAGE RATE CONTRACT FOR CONSTRUCTION
FAIRVIEW ROAD HUGHEY CREEK CULVERT CONSTRUCTION PROJECT

Contact Name: Kevin Rariden Phone: (541) 602-9166

Deliver Form to: Tillamook County Public Works' Office
Person Designated to Receive Form: Nicole Baldwin Phone: (503) 842-3419
Owner's Address: 503 Marolf Loop, Tillamook, Oregon 97141

Unless otherwise stated in the original solicitation, this document shall not be faxed. It is the responsibility of the bidders to separately submit this disclosure form and any additional sheets (if required), with the project name clearly marked, at the location indicated in the invitation to bid by the specified disclosure deadline. See invitation to bid for further details.

END OF BID FORM PART II

STATE OF Oregon)
COUNTY OF Tillamook)

The undersigned hereby certifies to the truth and accuracy of all statements, answers and data contained in this bid and application and hereby authorizes Tillamook County to make any necessary examinations or inquiries in order to make a determination to the qualifications and responsibility of the bidder. The undersigned has examined all parts of the Call for Bids and understands that it is completely discretionary with the county whether to accept or reject its bidder submitted pursuant thereto.

[Signature]
Signature of Bidder

Managing Member / Owner
Title

Sworn before me this 19 day of July, 2023.

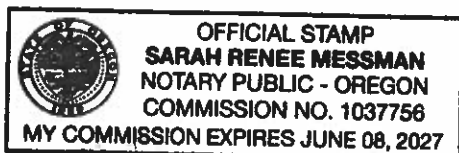

[Signature]
Notary Public for the State of Oregon
My commission expires on June 8, 2027

TILLAMOOK COUNTY
CALL FOR BIDS – PREVAILING WAGE RATE CONTRACT FOR CONSTRUCTION
FAIRVIEW ROAD HUGHEY CREEK CULVERT CONSTRUCTION PROJECT

LOCATION: FAIRVIEW ROAD MP 1.6, TILLAMOOK COUNTY

INITIAL ADVERTISEMENT DATE: July 11, 2023

SECTION 00010	2
CALL FOR BIDS.....	2
SECTION 00020	3
INVITATION TO BID.....	3
GENERAL.....	3
SECTION 00030	13
BID DOCUMENTS.....	13
PART I (BID FORM)	13
SECTION 00040	15
BID DOCUMENTS.....	15
PART II (FIRST-TIER SUB-CONTRACTOR DISCLOSURE FORM).....	15
SAMPLE CONTRACT WITH GENERAL CONDITIONS	17
PUBLIC CONTRACT PROVISIONS	25
SPECIFICATIONS AND PLANS	

TILLAMOOK COUNTY
CALL FOR BIDS – PREVAILING WAGE RATE CONTRACT FOR CONSTRUCTION
FAIRVIEW ROAD HUGHEY CREEK CULVERT CONSTRUCTION PROJECT

SECTION 00010
CALL FOR BIDS

This project consists of streambed excavation, assembly and installation of an owner furnished Contech Multi-Plate culvert, reconstruction of the road bed and approximately 85 feet paved surface. Note that the existing pipe has been removed and the road has been excavated. The engineer's estimate is between Zero Dollars (\$0) and One Hundred Fifty Thousand Dollars (\$150,000)

Specifications and bid forms may be viewed at Tillamook County Public Works, Attention Nicole Baldwin, 503 Marolf Loop, Tillamook, Oregon 97141 between 8:00 a.m. and 4:00 p.m., Monday through Thursday, local time. The specifications and bid forms may be obtained electronically, at no charge, by e-mailing nbaldwin@co.tillamook.or.us or may be purchased at a pre-paid cost of Fifty Dollars (\$50) payable only by check or money order to Tillamook County Public Works, 503 Marolf Loop, Tillamook, OR. 97141 between 8:00 a.m. and 4:00 p.m., Monday through Thursday, local time. (Allow two (2) workdays for reproduction of plans prior to them being mailed out to requesting contractors.) Each prospective contractor must provide full company name, address, contact name, phone and e-mail address at the time of request.

Bidders will not be required to be pre-qualified under ORS 279B.120.

This contract is for a project that is subject to ORS 279C.800 to 279C.870 (Prevailing Wage Law).

Sealed bids shall be submitted to: Tillamook County Public Works' Office, Attention: Nicole Baldwin, 503 Marolf Loop, Tillamook, Oregon 97141. Sealed bids shall be marked "FAIRVIEW ROAD HUGHEY CREEK CULVERT CONSTRUCTION PROJECT" and be submitted no later than 10:00 a.m. on Thursday, July 20, 2023. Bids received after this time shall be returned unopened. Bids may be withdrawn at any time, prior to opening, upon written request of the bidder. **NO BIDS WILL BE ACCEPTED BY WAY OF FAX OR ELECTRONIC DATA INTERCHANGE.**

All bids will be opened and read aloud in the Tillamook County Public Work's Office meeting room at the Tillamook County Public Works' Office at 10:05 a.m. on Thursday, July 20, 2023.

TILLAMOOK COUNTY
CALL FOR BIDS – PREVAILING WAGE RATE CONTRACT FOR CONSTRUCTION
FAIRVIEW ROAD HUGHEY CREEK CULVERT CONSTRUCTION PROJECT

SECTION 00020
INVITATION TO BID

GENERAL

1.1 STATEMENT OF WORK

1.1.1 This project consists of streambed excavation, assembly and installation of an owner furnished Contech Multi-Plate culvert, reconstruction of the road bed and approximately 85 feet paved surface. Note that the existing pipe has been removed and the road has been excavated. The engineer's estimate is between Zero Dollars (\$0) and One Hundred Fifty Thousand Dollars (\$150,000). Work is to be completed in all respects and in full conformity with the contract documents.

1.1.2 The project site is located at Fairview Road MP 1.6 and is available for inspection.

1.2 NOTICE TO BIDDERS

1.2.1 Sealed bids for this FAIRVIEW ROAD HUGHEY CREEK CULVERT CONSTRUCTION PROJECT will be received by the Tillamook County Public Works' Office, Attention: Nicole Baldwin, 503 Marolf Loop, Tillamook, Oregon 97141, no later than 10:00 a.m. on Thursday July 20, 2023. Bid opening will be conducted in the Tillamook County Public Works' Office, 503 Marolf Loop, Tillamook, Oregon 97141. Bids will be publicly opened and read aloud at 10:05 a.m. on Thursday, July 20, 2023.

1.2.2 In accordance with state law, Tillamook County uses and incorporates portions of the Oregon Attorney General's Model Public Contract Rules (Oregon Administrative Rules, Chapter 137, Division 46 (Public Contracting), Division 47 (Procurements for Goods or Services) and Division 49 (Public Contracts for Construction Services).

1.2.3 Vendors shall use recyclable products to the maximum extent economically feasible in the performance of the contract work set forth in this document. Bidder shall specify the minimum, if not exact, percentage of recycled paper in paper products or recycle product in products offered and both the post-consumer and secondary waste content regardless of whether the product meets what percentage of recycled material specified for recycled paper or recycled products in ORS 279A.010 and ORS 279A.125. For paper products the bidder shall also specify the fiber type. The contractor may certify a zero percent (0%) recycled paper or product.

TILLAMOOK COUNTY
CALL FOR BIDS – PREVAILING WAGE RATE CONTRACT FOR CONSTRUCTION
FAIRVIEW ROAD HUGHEY CREEK CULVERT CONSTRUCTION PROJECT

1.3 PRE-QUALIFICATIONS

- 1.3.1 For the purpose of this project the county elects not to request pre-qualifications of bidders. The submittal of a bid bond, a performance bond and a public works bond shall be required as specified within the contract documents.
- 1.3.2 The contractor and all sub-contractors who will perform work on this project will not be required to be licensed under ORS 468A.720 for asbestos abatement.

1.4 PRE-BID CONFERENCE

- 1.4.1 There will not be a pre-bid conference for this project.

1.5 CONSTRUCTION DOCUMENTS

- 1.5.1 Construction documents, consisting of those components outlined in the Table of Contents (Section 00010), may be examined at: Tillamook County Public Works' Office, 503 Marolf Loop, Tillamook, Oregon 97141.
- 1.5.2 Copies of construction documents obtained electronically, at no charge, by e-mailing nbaldwin@co.tillamook.or.us or maybe purchased at a pre-paid cost of Fifty Dollars (\$50) payable only by check or money order to Tillamook County Public Works, 503 Marolf Loop, Tillamook, Oregon 97141 between 8:00 a.m. and 4:00 p.m., Monday through Thursday, local time. (Allow two (2) workdays for reproduction of plans prior to them being mailed out to requesting contractors). Bona-fide prime bidders MUST register their business name, address and telephone/fax number when obtaining documents in order to receive any addenda or other pertinent information.

FAILURE TO REGISTER IS SOLELY THE RESPONSIBILITY OF THE
PROSPECTIVE BIDDER.

- 1.5.3 Bidders are advised to obtain copies of all portions of all bid documents as outlined in the table of contents. Neither the county nor engineer will be responsible for use of partial or incomplete sets of documents by prospective bidders.
- 1.5.4 Allow two (2) workdays for reproduction of plans prior to them being mailed out to requesting contractors.

TILLAMOOK COUNTY
CALL FOR BIDS – PREVAILING WAGE RATE CONTRACT FOR CONSTRUCTION
FAIRVIEW ROAD HUGHEY CREEK CULVERT CONSTRUCTION PROJECT

1.6 BID SUBMITTAL REQUIREMENTS

- 1.6.1 No bid will be considered unless fully completed in the manner provided in the invitation to bid upon the Bid Form provided by the county and accompanied by a bid bond, cashier's check or certified check executed in favor of Tillamook County, Oregon, in an amount not less than ten percent (10%) of the total amount of the bid. Bid bonds will be accompanied by power of attorney bearing the same date as the bond. Bid bond, cashier's check or certified check to be forfeited as a fixed and liquidated damage should bidder neglect or refuse to enter into a contract and provide suitable bond for the faithful performance of the work in the event the contract is awarded to them.
- 1.6.2 No bid will be considered unless the first-tier sub-contractor disclosure Form (Bid Form Part II) is submitted no later than 12:00 p.m. on Thursday, July 20, 2023 to the bid submission location indicated above (i.e. within two (2) working hours of the scheduled bid due date and time). The lunch hour is not considered a working hour as related to first-tier subcontractor disclosure. It is the responsibility of the bidder to submit the disclosure form and any additional sheets, with the project name clearly marked, at the location indicated by the specified disclosure deadline.

1.7 BID FORM

- 1.7.1 Bid Form (Part I) includes any attachments that may be required with the Bid Form.
- 1.7.2 Bids shall be submitted on the forms provided by the county.
- 1.7.3 All blanks on the Bid Form shall be filled in by typewriter or manually in ink.
- 1.7.4 Any interlineation, alteration or erasure must be initialed by the signer of the bid.
- 1.7.5 BIDDER SHALL MAKE NO ADDITIONAL STIPULATIONS ON THE BID FORM NOR QUALIFY THE BID IN ANY OTHER MANNER.
- 1.7.6 Each copy of the bid shall include the legal name of the bidder and shall be signed by the person or persons legally authorized to bind the bidder to a contract.
- 1.7.7 A bid submitted by an Agent shall have a current power of attorney attached certifying agent's authority to bind bidder.

TILLAMOOK COUNTY
CALL FOR BIDS – PREVAILING WAGE RATE CONTRACT FOR CONSTRUCTION
FAIRVIEW ROAD HUGHEY CREEK CULVERT CONSTRUCTION PROJECT

1.8 BID SECURITY

- 1.8.1 Each bid shall be accompanied with either a cashier's check, certified check or bid bond payable to Tillamook County in a specific amount not less than ten percent (10%) of the total proposed bid price. Bid bond shall be furnished by a bonding company licensed to do business in the State of Oregon. Bid bond shall be accompanied by power of attorney bearing the same date as the bond.
- 1.8.2 Security of the successful bidder to whom the contract is awarded will be returned when the bidder's formal written contract, performance and payment bond and certificate of insurance have been properly executed, delivered to and accepted by the county.
- 1.8.3 The county reserves the right to retain the bid security of the next two (2) lowest bidders until the low bidder enters into a contract with the county or until no more than forty-five (45) calendar days after the bid opening, whichever is shorter. Bid security of all other bidders will be returned as soon as practicable after the bid opening.
- 1.8.4 Any bidder with whom a contract is offered, who defaults in executing the contract or in furnishing the performance and payment bond and certificate of insurance within the time and in the manner required shall forfeit its bid security, in whole or in part, as liquidated damages, but not as a penalty, up to the full amount of the bid security or the difference between the low bid and the next acceptable bid, whichever is greater. In addition, the county shall be entitled to payment for damages and expenses, including attorney fees, with or without action, to enforce the county's rights hereunder.

1.9 SUBMISSION OF BIDS

- 1.9.1 All copies of the bid, the bid security and any other documents required to be submitted with the bid shall be enclosed in a sealed opaque envelope. The envelope shall be addressed to the county and shall be identified with the project name and the bidder's name and address.
- 1.9.2 If the bid is sent by mail, the sealed envelope shall be enclosed in a separate mailing envelope with the notation "BID ENCLOSED" on the face thereof.
- 1.9.3 Bids shall be sent to/deposited at or received by the Tillamook County Public Work' Office prior to the time and date for receipt of bids indicated in the invitation to bid for bids or any extension thereof made by addendum. Hand delivered bids shall be presented to: Tillamook County

TILLAMOOK COUNTY
CALL FOR BIDS – PREVAILING WAGE RATE CONTRACT FOR CONSTRUCTION
FAIRVIEW ROAD HUGHEY CREEK CULVERT CONSTRUCTION PROJECT

Public Works, Attention Nicole Baldwin, 503 Marolf Loop, Tillamook,
Oregon 97141

- 1.9.4 Bids received after the time and date for receipt of bids (bid closing) will be returned unopened.
 - 1.9.5 Bidders shall assume full responsibility for timely delivery at location designated for receipt of bids.
 - 1.9.6 Oral, telephone, facsimile or telegraph bids are invalid and will not receive consideration.
 - 1.9.7 A bid may not be modified, withdrawn or cancelled by the bidder for forty-five (45) days following the time and date designated for the receipt of bids and bidder so agrees in submitting a bid.
- 1.10 ADDENDA
- 1.10.1 Addenda are written or graphic instruments issued by the county or engineer prior to the execution of the contract which modify or interpret the bidding documents, by additions, deletions, clarifications or corrections. Addenda will become part of the contract documents when the construction contract is executed.
- 1.11 ADDITIVE ALTERNATE BID
- 1.11.1 An additive alternate bid (authorized by the county, if any) is an amount stated in the bid to be added to the amount of the base bid if the county, in its sole discretion, elects to authorize the corresponding change in project scope or materials or methods of construction described in the bidding documents.
- 1.12 PREVAILING WAGE RATES
- 1.12.1 If this contract is for a public work subject to ORS 279C.800 to 279C.870:
 - 1.12.1.1 No bid will be received or considered by the county unless the bid contains a statement by the bidder as part of its bid that the provisions of ORS 279C.840 or 40 USC 276a are to be complied with.
 - 1.12.1.2 The successful bidder and all subsequent subcontractors shall comply with ORS 279C.845 wage rate requirements and produce appropriate certificates that they have complied.
 - 1.12.1.3 Oregon Prevailing Wage Rate Bulletin date January 5, 2023 as amended, applies to this project.

TILLAMOOK COUNTY
CALL FOR BIDS – PREVAILING WAGE RATE CONTRACT FOR CONSTRUCTION
FAIRVIEW ROAD HUGHEY CREEK CULVERT CONSTRUCTION PROJECT

1.13 RESIDENT BIDDER

1.13.1 The county will not consider a bid proposal unless it contains a statement as to whether a bidder is a resident bidder as defined in ORS 279A.120.

1.14 CONTRACTOR REGISTRATION

1.14.1 The county will not receive or consider a bid proposal for a construction contract unless the bidder is registered with the Oregon Construction Contractors Board or licensed by the State Landscape Contractors Board as required by ORS 671.530.

1.15 PUBLIC WORKS BOND

1.15.1 Before starting work, the contractor and sub-contractors shall each file with the Oregon Construction Contractors Board (CCB) and maintain in full force and effect, a separate public works bond, in the amount of Thirty Thousand Dollars (\$30,000) unless otherwise exempt, as required by Oregon Laws 2005, Chapter 360 and OAR 839-025-0015. The contractor shall verify subcontractors have filed a public works bond before the subcontractor begins work.

1.16 LOWEST RESPONSIBLE BIDDER

1.16.1 In determining the lowest responsible bidder, the county will utilize standards of responsibility as outlined in ORS 279C.375. This may include referencing the CCB website to determine "contractors not qualified to hold or bid upon public contracts or public improvement projects". The internet URL for the CCB home page is: <http://www.oregon.gov/CCB>. Verification of current list information may be followed up with telephone contact with the CCB Office.

1.17 RIGHTS OF THE BOARD

1.17.1 It is the intent of the Tillamook County Board of Commissioners to award a contract to the lowest responsible bidder provided the bid has been submitted in accordance with the requirements of the bidding documents and does not exceed the funds available. The Tillamook County Board of Commissioners shall have the right to waive informalities or irregularities in a bid received and to accept the bid which, in the board's judgment, is in the county's own best interests.

1.17.2 The county may reject any bid not in compliance with all prescribed public contracting procedures, requirements and other applicable laws including the requirement to demonstrate the bidder's responsibility under ORS

TILLAMOOK COUNTY
CALL FOR BIDS – PREVAILING WAGE RATE CONTRACT FOR CONSTRUCTION
FAIRVIEW ROAD HUGHEY CREEK CULVERT CONSTRUCTION PROJECT

279C.375(3)(b). The county may reject for good cause, any or all bids upon a finding of the county that it is in the public interest to do so.

1.18 EXISTING CONDITIONS AND DIMENSIONS

1.18.1 Field verify existing conditions prior to bid opening. Request clarification from the engineer for conditions found that are in conflict with information shown on the drawings or specified PRIOR TO BID OPENING.

1.18.2 Field verify existing dimensions prior to bid opening. Do not scale measurements or dimensions from the drawings. Bid errors resulting from scaled measurements/dimensions shall be solely the responsibility of the bidder.

1.18.3 Field verify dimensions of new openings, new construction and new equipment/devices prior to ordering any material components subject to field dimensions. Successful bidder is responsible for dimensions which shall be confirmed and correlated at the project site for compatibility with project components intended to be a part of the work.

1.18.4 Failure to field verify existing conditions and new or existing dimensions by the bidder will not be reason to change the contract sum after award of a contract to the successful bidder.

1.18.5 Field verify existing structure materials prior to bid opening. Request clarification from the engineer for materials found that are in conflict with the information shown on the drawings or specified prior to bid opening. Bid errors resulting from failure to field verify existing structure materials shall be solely the responsibility of the successful bidder.

1.18.6 Failure to field verify existing conditions by the bidder will not be reason to change the contract sum after award of a contract to the successful bidder.

1.19 BIDDER'S REPRESENTATIONS

1.19.1 Each bidder, by making their bid, represents that they have read and understand **ALL** the bidding documents as outlined in the table of contents (Section 00010) and their bid is made in accordance therewith. The bidder, by making their bid represents that they have visited the site and familiarized themselves with the local conditions under which the work is to be performed. The bidder, by making their bid, represents that the bid is based upon the products, systems and equipment described in the bidding documents WITHOUT EXCEPTIONS.

TILLAMOOK COUNTY
CALL FOR BIDS – PREVAILING WAGE RATE CONTRACT FOR CONSTRUCTION
FAIRVIEW ROAD HUGHEY CREEK CULVERT CONSTRUCTION PROJECT

1.19.2 Documents are available as specified herein. Neither the county nor engineer will be responsible for distribution of those documents. **CONTRACTOR IS ADVISED TO EXAMINE ALL PORTIONS OF THE DOCUMENTS AS THEY FORM THE CONTRACT.** Neither county nor engineer will be responsible for use by the contractor or sub-contractor of partial or incomplete sets of documents.

1.20 DISCREPANCIES AND AMBIGUITIES

1.20.1 Discrepancies between drawings and specifications, omissions, doubt as to meaning and other questions should be brought to the attention of the county or engineer not less than seven (7) days prior to bid opening and they will be answered by addendum addressed to all prime bidders of record. Questions received less than seven (7) days before the bid opening date cannot be answered by addendum.

1.20.2 Protests of bid specifications shall be presented, in writing, to the Tillamook County Counsel, 201 Laurel Avenue, Tillamook, Oregon 97141, at least seven (7) calendar days prior to the bid closing. No protests against the award because of the content of bid specifications shall be considered after this deadline. Any written protest shall include the reason(s) for protest and any proposed changes to the specifications.

1.20.3 All addenda issued during time of bidding will be incorporated into the contract. **NEITHER THE COUNTY NOR ENGINEER WILL BE RESPONSIBLE FOR ORAL INTERPRETATIONS.** The engineer shall make all decisions regarding discrepancies between drawings and specifications, based upon the engineer's determination as to which of the contract documents represents the original intent.

1.20.4 Addenda will be issued to the prime bidders of record registered as signing for bid documents. Neither the county nor engineer will be responsible for the distribution of Addenda to sub-contractors.

1.21 PRODUCT SUBSTITUTIONS

1.21.1 Discussion of product substitutions is outlined in the project specifications, if applicable.

1.22 NOTICE OF INTENT TO AWARD CONTRACT

1.22.1 When a decision is made regarding to whom the county intends to award the contract, the county will provide written notice to all project bidders of the county's intent to award the contract in accordance with OAR 137-047-0610.

TILLAMOOK COUNTY
CALL FOR BIDS – PREVAILING WAGE RATE CONTRACT FOR CONSTRUCTION
FAIRVIEW ROAD HUGHEY CREEK CULVERT CONSTRUCTION PROJECT

1.22.2 This notice shall constitute a final decision of Tillamook County, if no written protest of the notice of intent to award, if filed with Tillamook County at Tillamook County Counsel, 201 Laurel Avenue, Tillamook, Oregon 97141, within seven (7) calendar days of the date of this notice of intent to Award pursuant to local contracting rules.

1.23 INSTRUCTIONS FOR FIRST-TIER SUB-CONTRACTOR DISCLOSURE

1.23.1 The disclosure deadline for submission of the first-tier sub-contractor disclosure form is stated on the Bid Form (Part II): 12:00 p.m. on Thursday, July 20, 2023. (i.e., within two (2) working hours of the scheduled bid due date and time). The submission location is indicated on the Part II Bid Form.

The following is copied verbatim from OAR 137-049-0360:

"Instructions for First-Tier Sub-contractor Disclosure."

Bidders are required to disclose information about certain first-tier sub-contractors when the contract value for a public improvement is greater than One Hundred Thousand Dollars (\$100,000) (see ORS 279C.370). Specifically, when the contract amount of a first-tier sub-contractor furnishing labor or labor and materials would be greater than or equal to: (i) five percent (5%) = of the project bid, but at least Fifteen Thousand Dollars (\$15,000), or (ii) Three Hundred Fifty Thousand Dollars (\$350,000) regardless of the percentage, the bidder must disclose the following information about that subcontract either in its bid submission, or within two (2) hours after bid closing:

The sub-contractor's name;

The category of work that the sub-contractor would be performing; and

The dollar value of the sub-contract. If the bidder will not be using any sub-contractors that are subject to the above disclosure requirements, the bidder is required to indicate "NONE" on the accompanying form.

THE CONTRACTING AGENCY MUST REJECT A BID IF THE BIDDER FAILS TO SUBMIT THE DISCLOSURE FORM WITH THIS INFORMATION BY THE STATED DEADLINE (SEE OAR 137-049-0360).

1.23.2 Submission. A bidder shall submit the disclosure form required by this rule either in its bid submission, or within two (2) working hours after bid closing in the manner specified by the ITB.

1.23.3 Responsiveness. Compliance with the disclosure and submittal requirements of ORS 279C.370 and this rule is a matter of responsiveness. Bids that are submitted by bid closing, but for which the disclosure submittal has not been made by the specified deadline, are not responsible and shall not be considered for contract award.

TILLAMOOK COUNTY
CALL FOR BIDS – PREVAILING WAGE RATE CONTRACT FOR CONSTRUCTION
FAIRVIEW ROAD HUGHEY CREEK CULVERT CONSTRUCTION PROJECT

1.24 WORKERS' COMPENSATION INSURANCE

1.24.1 The successful bidder and all subsequent sub-contractors shall comply with ORS 656.017, Oregon Workers' Compensation Law and produce appropriate certificates that they have complied.

1.24.2 All subject employers working under this contract shall either be employers that will comply with ORS 656.017 or employers that are exempt under ORS 656.126.

END OF INVITATION TO BID

Approved as to form and content this 29th day of June, 2023.

Contract Officer

HUGHEY CREEK CULVERT REPLACEMENT

FAIRVIEW ROAD MILE POST 1.61 - (COUNTY ROAD #761)

TILLAMOOK COUNTY PUBLIC WORKS DEPARTMENT

503 MAROLF LOOP

TILLAMOOK, OR 97141

(503) 842-3419

T01S R09W

SECTIONS 22 & 27

LAT: 45.46306

LONG: 123.76518

PROJECT VICINITY

FISH SALVAGE COORDINATION
 Tillamook Bay Estuary Partnership
 Conrad Ely, Habitat Restoration Project Manager
 Office: 503-457-4114
 Conrad@TBNEP.org

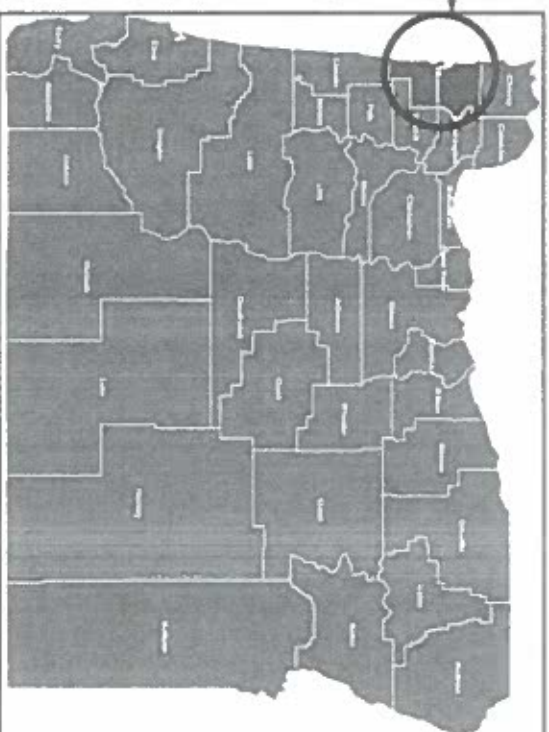
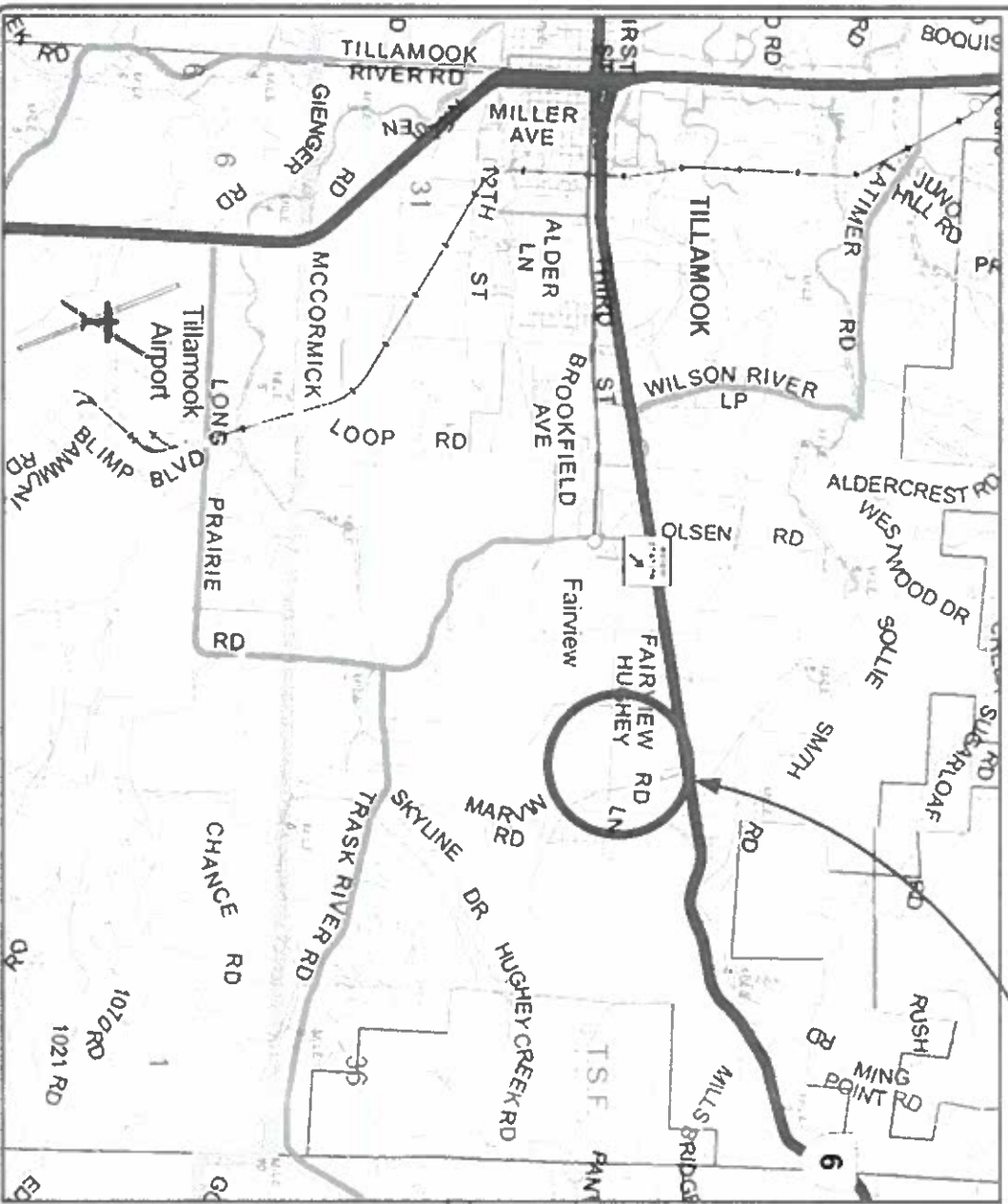

UTILITY CONTACTS

Charter Communications
 1014 Pacific Ave.
 Tillamook, OR 97141
 (503) 374-0635
 steven.fournier@charter.com
 Steve Fournier

Lumen Technologies
 740 State St. RM #407
 Salem, OR 97301
 (971) 346-4141
 Travis Vaughn
 Travis.Vaughn@lumen.com

Fairview Water District
 403 Marolf Loop Rd.
 Tillamook, OR 97141
 (503) 842-4333
 David Pace, Water Master
 davidpace@fairviewwater.com

Tillamook Peoples Utility District
 1115 Pacific Ave.
 Tillamook, OR 97141
 (503) 842-2535
 Zachary Hudspeth, Eng. Sup.
 zhudspeth@tpud.org

SHEET INDEX

SHT NO.	DESCRIPTION
1	COVER SHEET
2	EXISTING CONDITIONS - SURVEY
3	TYP ROAD SECTION & PROJECT NOTES
4	HUGHEY CREEK PLAN & PROFILE
5	GUARDRAIL DETAIL
6	ROAD SECTIONS WITH DETAILS
7	ROAD SECTIONS WITH DETAILS
8	STREAM ISOLATION & ESC PLAN
9	STREAM RESTORATION
1 OF 5	CONTECH ES ALSP ASSEMBLY
2 OF 5	CONTECH-ES ASSEMBLY DETAIL -1
3 OF 5	CONTECH-ES ASSEMBLY DETAIL -2
4 OF 5	CONTECH-ES ASSEMBLY DETAIL -3
5 OF 5	CONTECH-ES ASSEMBLY DETAIL -4
5 OF 5	CONTECH-ES ASSEMBLY DETAIL -5



NOTICE TO ALL CONTRACTORS:
 AS DEFINED IN OREGON REVISED STATUTE CHAPTER 757 AND IMPLEMENTED UNDER OREGON ADMINISTRATIVE RULE CHAPTER 952, DIVISION 1, YOU ARE REQUIRED TO CONTACT THE OREGON UTILITY NOTIFICATION CENTER PRIOR TO CONDUCTING ANY EXCAVATION ACTIVITIES ON THIS PROJECT. UTILITY LOCATES CAN BE REQUESTED ONLINE, BY DIALING 811 OR CALLING THE OUNC OFFICE DIRECT AT 1-800-332-2344.



DESN	REN	NO	DATE	DESCRIPTION	BY
2	05-05-23			SUBMIT FOR AGENCY PRELIMINARY REVIEW	
1	02-28-23			EDITS TO SUPPORT AGENCY COMMENTS	REN

HUGHEY CREEK CULVERT
 TILLAMOOK, OREGON
 ALUMINUM STRUCTURAL PLATE (ALSP) CULVERT REPLACEMENT

COVER SHEET

1 OF 9 SHEETS
 JOB NUMBER 23.0761.161

PNT NO	NORTHING	EASTING	ELEV	DESC
1	672160.518	7364487.259	73.77	TCSO CNTRL
2	671652.676	7364471.326	90.74	TCSO CNTRL
300	671854.357	7364330.557	88.53	CL 3+50
301	671849.073	7364430.418	85.12	CL 4+50
302	671839.627	7364630.192	88.78	CL 6+50
303	671835.236	7364730.096	92.98	CL 7+50
9137	671834.188	7364485.390	84.48	80D NAIL
9138	671853.286	7364631.787	88.36	TCSO CNTRL
9139	671813.721	7364944.031	99.09	80D NAIL

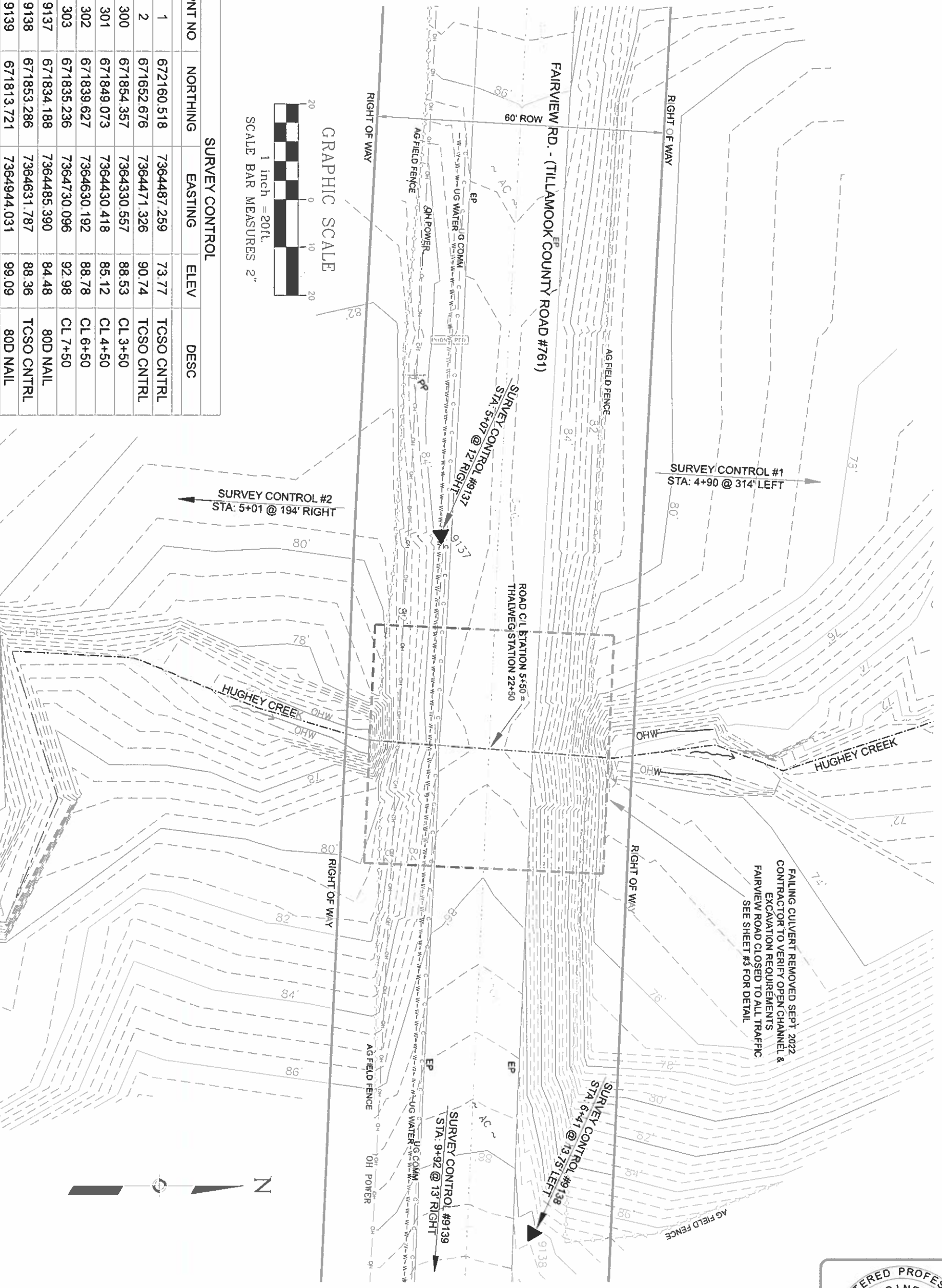
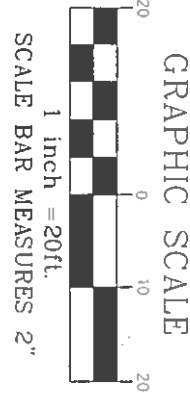

FAILING CULVERT REMOVED SEPT. 2022
 CONTRACTOR TO VERIFY OPEN CHANNEL &
 EXCAVATION REQUIREMENTS
 FAIRVIEW ROAD CLOSED TO ALL TRAFFIC
 SEE SHEET #3 FOR DETAIL



SHEET
 2 OF 9
 JOB NUMBER
 23.0761.161

HUGHEY CREEK CULVERT
 ALUMINUM STRUCTURAL PLATE (ALSP) CULVERT REPLACEMENT
 TILLAMOOK, OREGON
EXISTING CONDITIONS SURVEY

DESIGN	REVISION	DATE	DESCRIPTION
DESIGN	REN	2 05-05-23	SUBMIT FOR AGENCY PRELIMINARY REVIEW
DRN	REN	1 02-28-23	EDITS TO SUPPORT AGENCY COMMENTS
CKD	CTL	NO	DATE
DATE:	JAN 23		

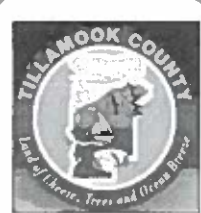

REGISTERED PROFESSIONAL
ENGINEER
 92764PE
 OREGON
 6-29-23
 SEPT. 12, 2017
 CHRISTOPH T. LAITY
 EXPIRES: 12/31/2024

GENERAL NOTES:

1. TILLAMOOK COUNTY PUBLIC WORKS (TCPW) SUMMER HOURS ARE MONDAY-THURSDAY FROM 7:00 AM TO 5:30 PM. WINTER HOURS ARE MONDAY - FRIDAY FROM 7:30 AM TO 4:00 PM. OFFICE PHONE IS (503) 842-3419.
2. CENTRAL COUNTY SHOP: 503 MAROLF LOOP ROAD, TILLAMOOK OR, 97141
3. NORTH COUNTY SHOP: 13155 D STREET, NEHALEM, OR 97131; 503-368-5686
4. SOUTH COUNTY SHOP: 34500 HIGHWAY 101 SOUTH, CLOVERDALE, OR 97122; 503-392-3660.
5. CONTRACTOR IS REQUIRED TO CONFORM TO THE 2021 OREGON STANDARD SPECIFICATION FOR CONSTRUCTION AND TILLAMOOK COUNTY PUBLIC WORKS (TCPW) REQUIREMENTS FOR ALL MATERIALS AND WORK. TILLAMOOK COUNTY PUBLIC WORKS REQUIREMENTS GOVERN IN THE EVENT OF A CONFLICT.
6. EXISTING UNDERGROUND UTILITIES SHOWN ARE FROM THE BEST INFORMATION AVAILABLE. THIS INFORMATION IS APPROXIMATE AND MAY BE INCOMPLETE. CONTRACTOR RESPONSIBLE TO CONTACT OREGON ONE CALL FOR PROJECT UTILITY LOCATIONS.
7. MATERIAL REMOVED FROM THE PROJECT SITE BECOMES THE PROPERTY OF THE CONTRACTOR UNLESS OTHERWISE IDENTIFIED. IT IS CONTRACTOR'S SOLE RESPONSIBILITY TO DISPOSE OF MATERIAL IN A LEGAL AND SAFE MANNER FOLLOWING APPLICABLE GOVERNING RULES.
8. CONTRACTOR IS REQUIRED TO OBTAIN AND COMPLY WITH ALL APPLICABLE PERMITS & LICENSES.
9. INSPECTION CONDUCTED BY TCPW STAFF DOES NOT RELIEVE THE CONTRACTOR'S OBLIGATIONS TO LOCAL, STATE, OR FEDERAL LAWS, CODES, AGENCY REQUIREMENTS, OR PERMIT REQUIREMENTS.
10. CONTRACTOR IS RESPONSIBLE FOR SITE SECURITY AND SAFETY.
11. CONTRACTOR IS RESPONSIBLE FOR STAGING AREAS NOT OTHERWISE IDENTIFIED. COUNTY IS NOT RESPONSIBLE FOR PRIVATE AGREEMENTS BETWEEN THE CONTRACTOR AND PRIVATE LANDOWNERS.
12. CONTRACTOR IS LIMITED TO WORKING WITHIN THE RIGHT-OF-WAY UNLESS EASEMENT OR PRIVATE AGREEMENT EXISTS.
13. CONTRACTOR IS REQUIRED TO MAINTAIN ONE COMPLETE SET OF APPROVED CONSTRUCTION PLANS ON SITE.
14. CONTRACTOR IS SOLELY RESPONSIBLE FOR TEMPORARY EROSION CONTROL MEASURES.
15. CONTRACTOR IS RESPONSIBLE FOR ALL CONSTRUCTION STAKING AND GRADE CONTROL.
16. PERPENDICULAR NEAT LINE ASPHALT SAW CUTS ARE REQUIRED A MINIMUM OF TWO FEET BEYOND THE LIMITS OF EXCAVATION.
17. RIGHT OF WAY AND PROPERTY LINES SHOWN ON PLANS ARE APPROXIMATE.

PROJECT NOTES:

1. CONTRACTOR IS REQUIRED TO REVIEW THE OWNER PROVIDED MATERIALS STORED AT TCPW'S CENTRAL SHOP LOCATED AT 503 MAROLF LOOP ROAD, TILLAMOOK, OR, 97141. CALL (503) 842-3419 TO SCHEDULE THE VISIT.
2. NOTIFY TCPW ENGINEERING STAFF 48 HOURS IN ADVANCE OF COMMENCEMENT OF WORK.
3. WORK HOURS ARE MONDAY THROUGH THURSDAY FROM 7AM TO ½ HOUR PRIOR TO SUNSET.
4. DE-WATERING PLAN: THE CONTRACTOR IS RESPONSIBLE FOR DE-WATERING OPERATIONS THAT MAY BE NECESSARY TO ADEQUATELY REMOVE WATER SO THAT CONSTRUCTION ACTIVITIES CAN BE COMPLETED AS SPECIFIED. THE CONTRACTOR IS RESPONSIBLE FOR CONVEYANCE AND DISPOSAL OF WATER TO SURFACE WATERCOURSE IF NEEDED.
5. THERE ARE POWER POLES NEAR THE EXCAVATION. EXTRA CAUTION MUST BE ADHERED TO.
6. TESTING:
 - A. ROAD COMPACTION TO UNYIELDING STATE. PROOF ROLL OBSERVED & VERIFIED BY COUNTY ENGINEERING STAFF TO VERIFY COMPACTION REQUIRED.
 - B. AGGREGATES: PROVIDE MATERIAL SOURCE FOR AGGREGATE
 - C. SIEVE AND GRADATIONS: NOT REQUIRED
 - D. ATTERBERG & PROCTORS: NOT REQUIRED
 - E. DENSITY & MOISTURE CONTENT TESTING: NOT REQUIRED
 - F. NO OTHER TESTING REQUIREMENTS
7. IN-WATER WORK WINDOW: JULY 1ST THRU SEPTEMBER 15TH.
8. SURVEY MONUMENT BOXES: NONE IDENTIFIED.
9. UTILITY RISERS TO BE ADDED: NONE IDENTIFIED.
10. PUBLIC NOTIFICATION PLAN: NOT REQUIRED.
11. RECORD DRAWINGS: NOT REQUIRED.

FISH SALVAGE COORDINATOR - (FSC)
 Tillamook Bay Estuary Partnership
 Conrad Ely, Habitat Restoration
 Project Manager
 Office: 503-457-4114

NOTE:
 CONTRACTOR SHALL OBTAIN ANY AND ALL REQUIRED CONSTRUCTION EASEMENTS AND PERMITS PRIOR TO COMMENCEMENT OF CONSTRUCTION.

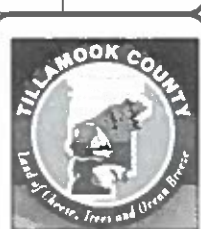
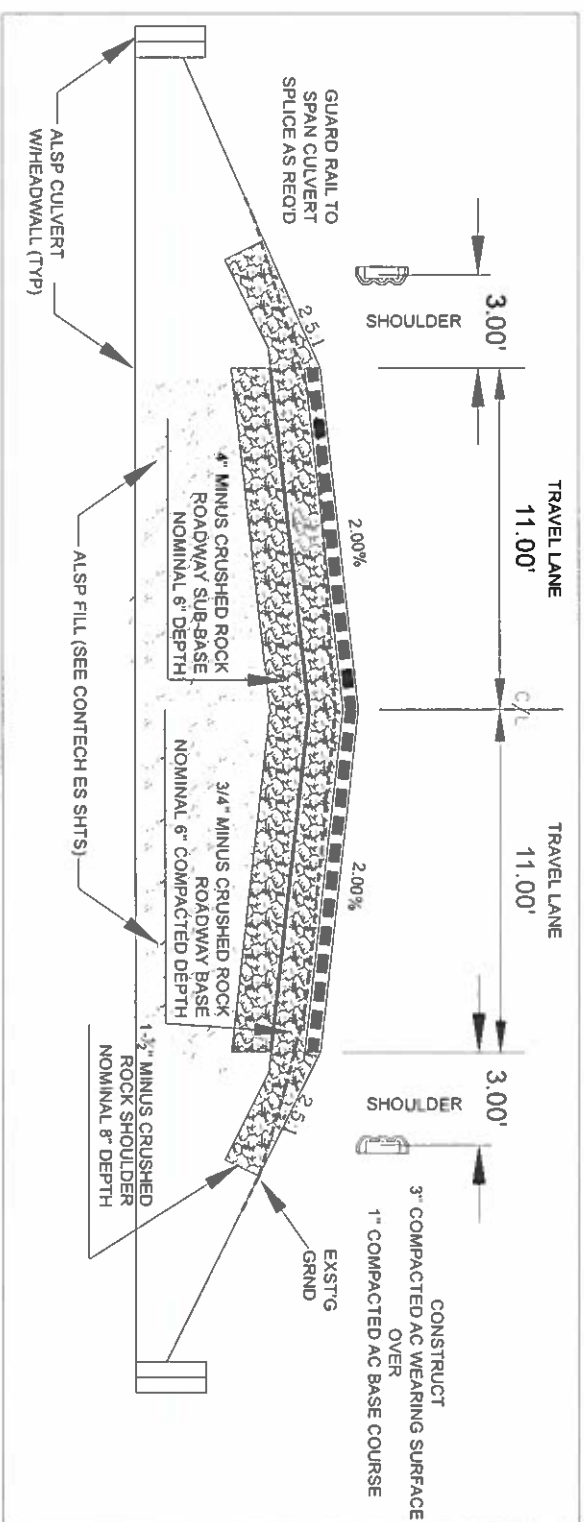
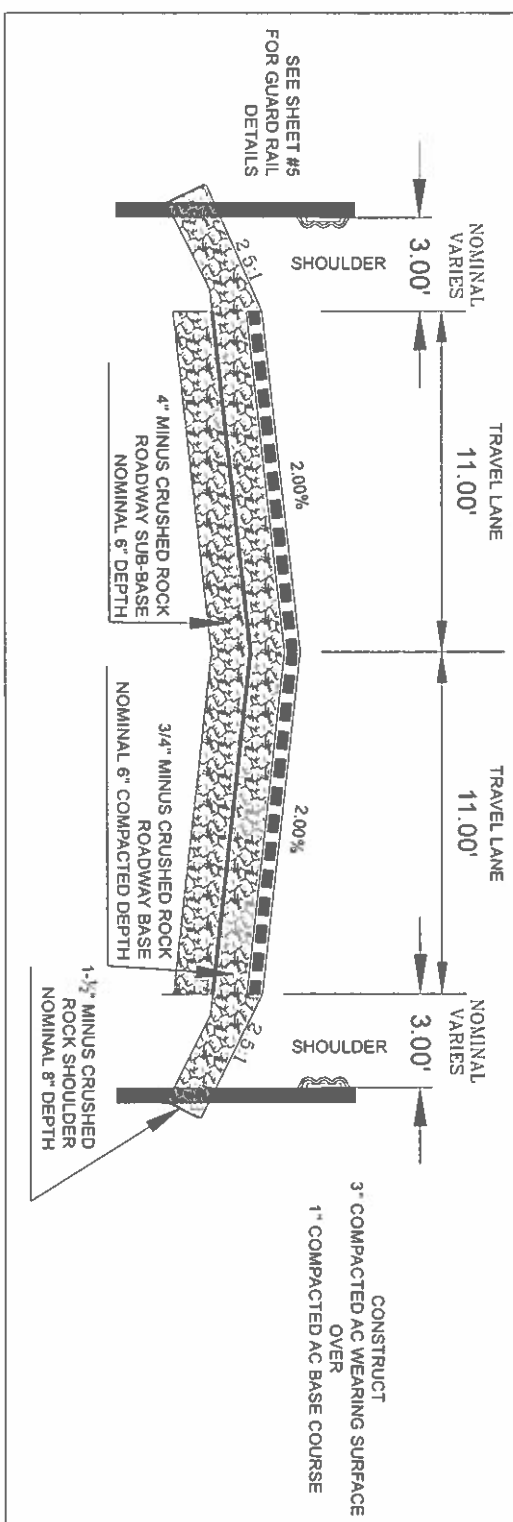

NO.	DATE	DESCRIPTION	BY
1	05-05-23	SUBMIT FOR AGENCY PRELIMINARY REVIEW	REN
2	02-28-23	EDITS TO SUPPORT AGENCY COMMENTS	REN
3			
4			
5			
6			
7			
8			
9			
10			
11			
12			
13			
14			
15			
16			
17			

HUGHEY CREEK CULVERT TILLAMOOK, OREGON
 ALUMINUM STRUCTURAL PLATE (ALSP) CULVERT REPLACEMENT

PROJECT NOTES & TYPICAL ROAD REPAIR SECTIONS

SHEET 3 OF 9
 JOB NUMBER 23.0761.161

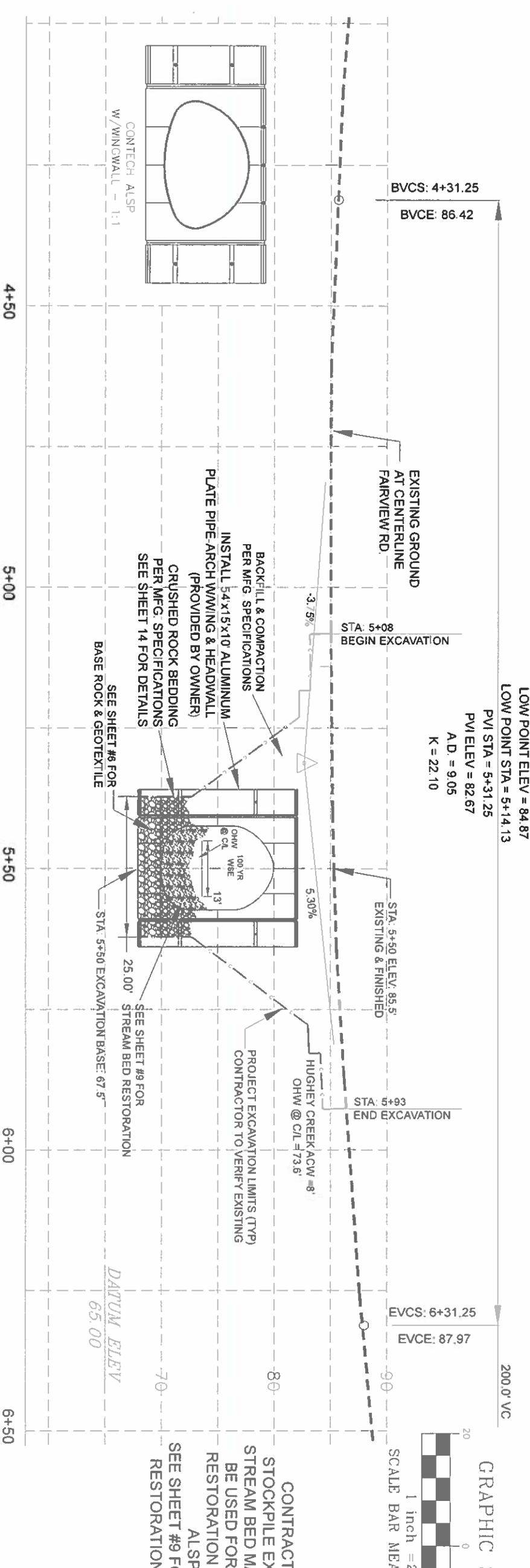
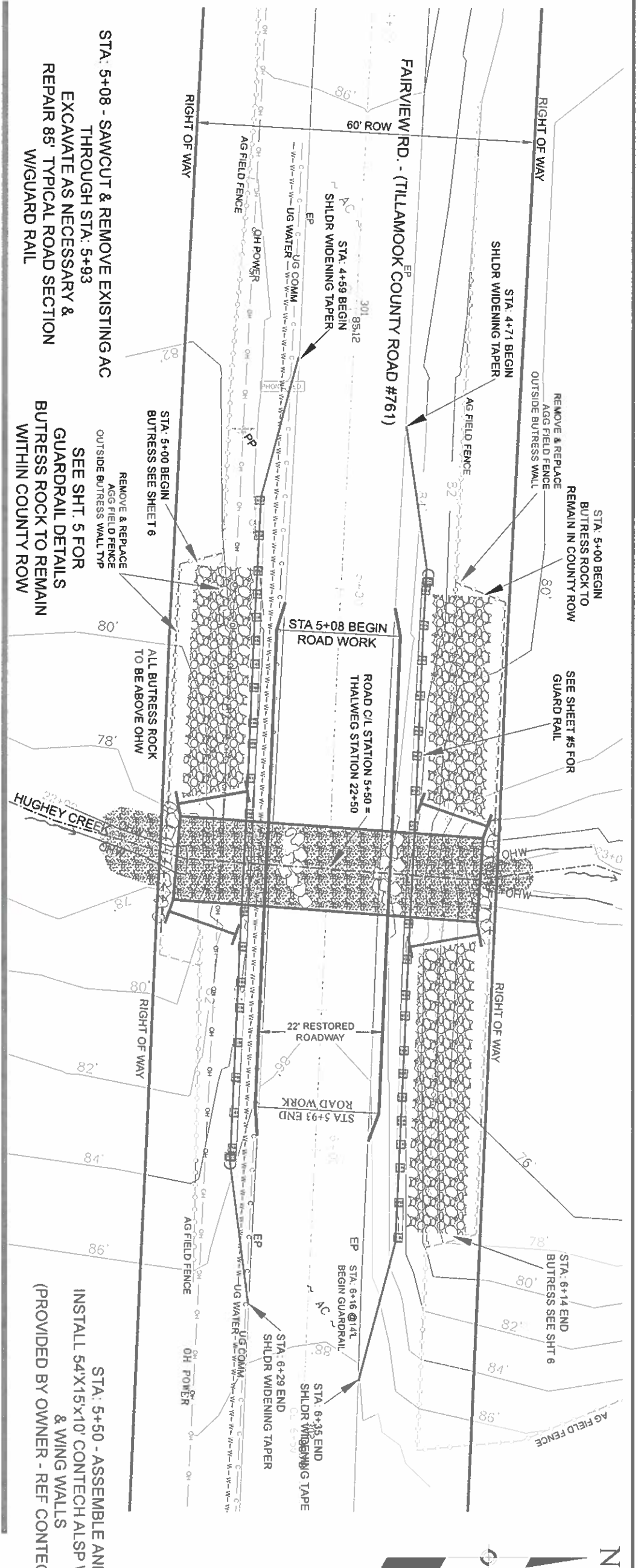

STA: 5+08 - SAWCUT & REMOVE EXISTING AC THROUGH STA: 5+93 EXCAVATE AS NECESSARY & REPAIR 85' TYPICAL ROAD SECTION W/GUARD RAIL

SEE SHT. 5 FOR GUARDRAIL DETAILS BUTRESS ROCK TO REMAIN WITHIN COUNTY ROW

STA: 5+50 - ASSEMBLE AND INSTALL 54'X15'X10' CONTECH ALSP WITH HEAD & WING WALLS (PROVIDED BY OWNER - REF CONTECH SHEETS)

LOW POINT ELEV = 84.87
 LOW POINT STA = 5+14.13
 PVI STA = 5+31.25
 PVI ELEV = 82.67
 A.D. = 9.05
 K = 22.10

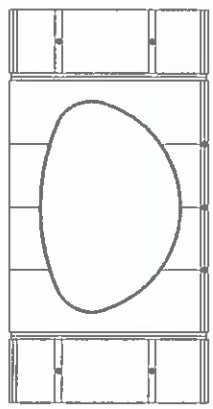
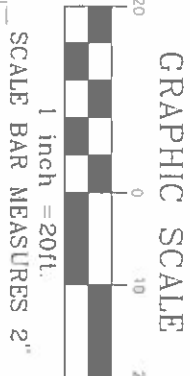

EXISTING GROUND AT CENTERLINE FAIRVIEW RD.
 STA: 5+08 BEGIN EXCAVATION
 STA: 5+50 ELEV: 85.5' EXISTING & FINISHED
 STA: 5+93 END EXCAVATION
 HUGHEY CREEK ACW = 8' OHW @ C/L = 73.8'

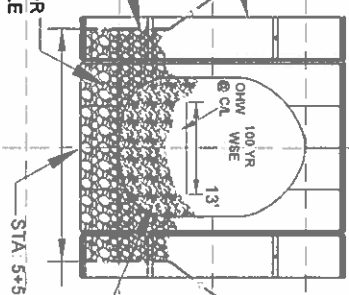

CONTRACTOR TO STOCKPILE EXCAVATED STREAM BED MATERIAL TO BE USED FOR STREAM RESTORATION THROUGH ALSP.
 SEE SHEET #9 FOR STREAM RESTORATION DETAILS

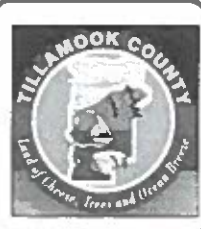

NO	DATE	DESCRIPTION	BY
2	05-05-23	SUBMIT FOR AGENCY PRELIMINARY REVIEW	REN
1	02-28-23	EDITS TO SUPPORT AGENCY COMMENTS	REN
NO			

HUGHEY CREEK CULVERT	TILLAMOOK, OREGON
ALUMINUM STRUCTURAL PLATE (ALSP) CULVERT REPLACEMENT	
PLAN & PROFILE	

SHEET 4 OF 9
 JOB NUMBER 22.0761.161

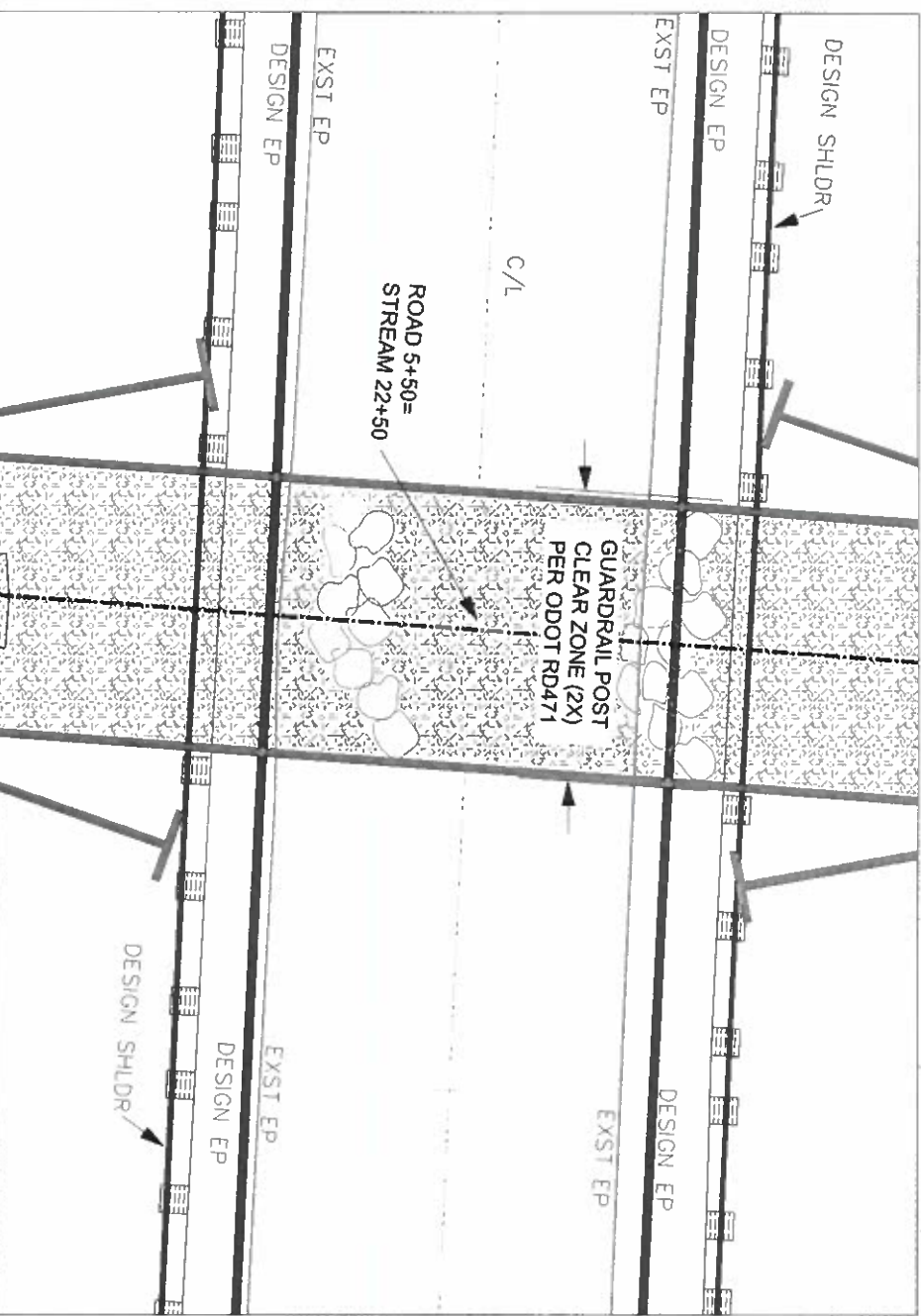
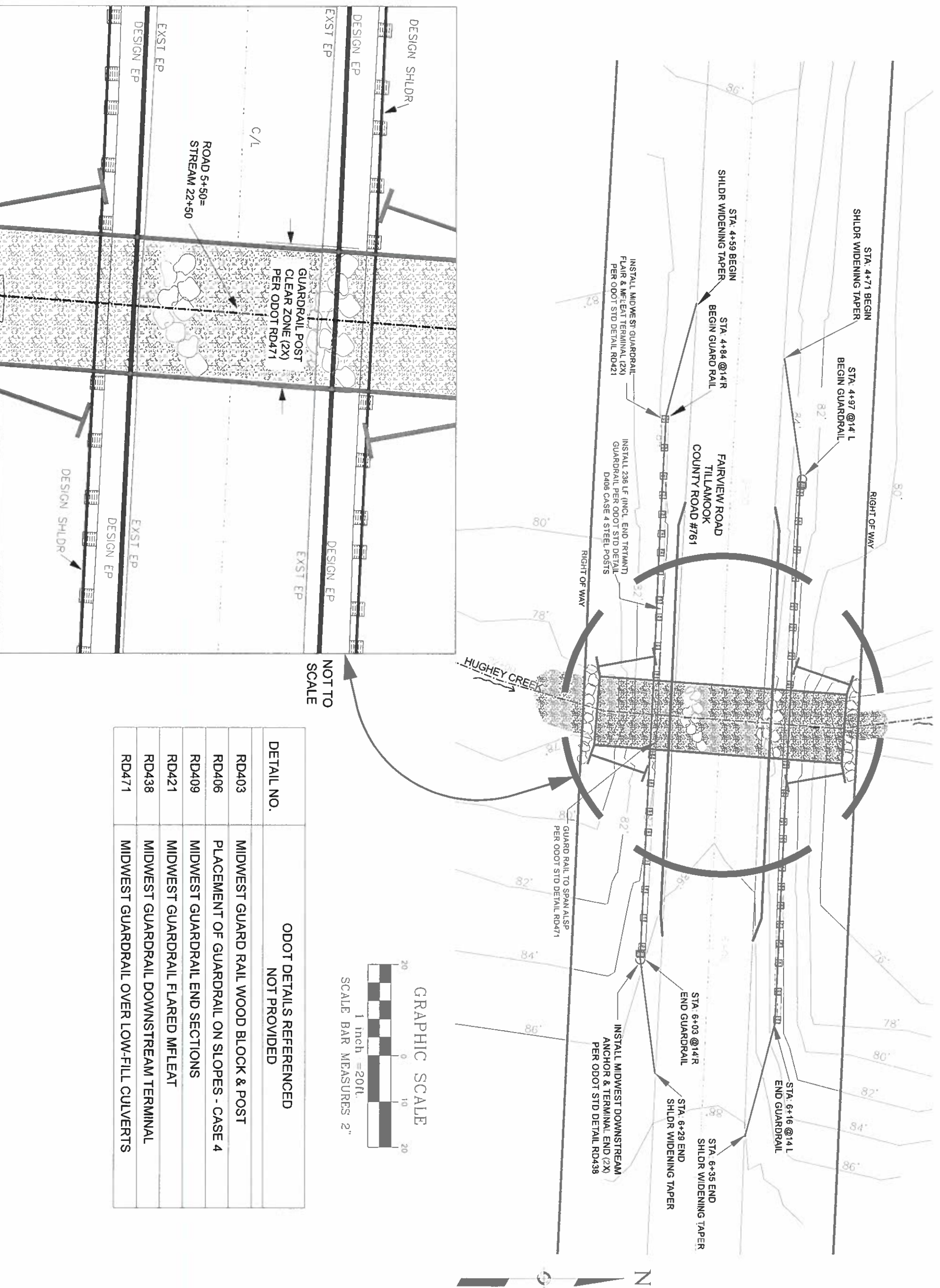

NOT TO SCALE

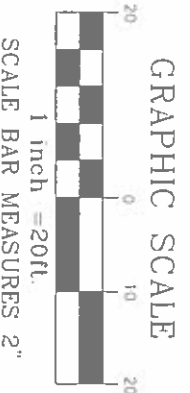

DETAIL NO.	ODOT DETAILS REFERENCED NOT PROVIDED
RD403	MIDWEST GUARD RAIL WOOD BLOCK & POST
RD406	PLACEMENT OF GUARDRAIL ON SLOPES - CASE 4
RD409	MIDWEST GUARDRAIL END SECTIONS
RD421	MIDWEST GUARDRAIL FLARED MFLREAT
RD438	MIDWEST GUARDRAIL DOWNSTREAM TERMINAL
RD471	MIDWEST GUARDRAIL OVER LOW-FILL CULVERTS

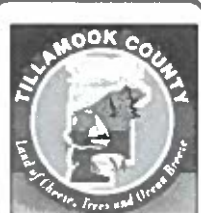

NO.	DATE	DESCRIPTION	BY
1	05-05-23	SUBMIT FOR AGENCY PRELIMINARY REVIEW	REN
2	02-28-23	EDITS TO SUPPORT AGENCY COMMENTS	REN

HUGHEY CREEK CULVERT TILLAMOOK, OREGON
ALUMINUM STRUCTURAL PLATE (ALSP) CULVERT REPLACEMENT

GUARDRAIL DETAIL

SHEET 5 OF 14
JOB NUMBER 22.0761.161

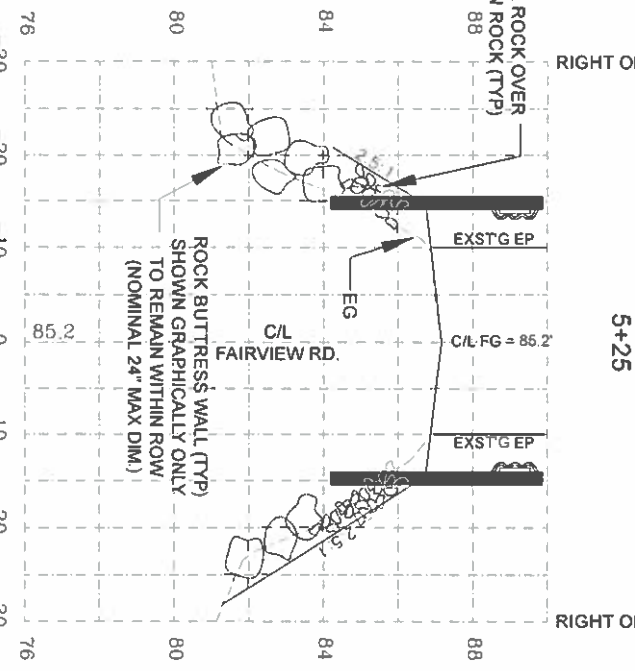
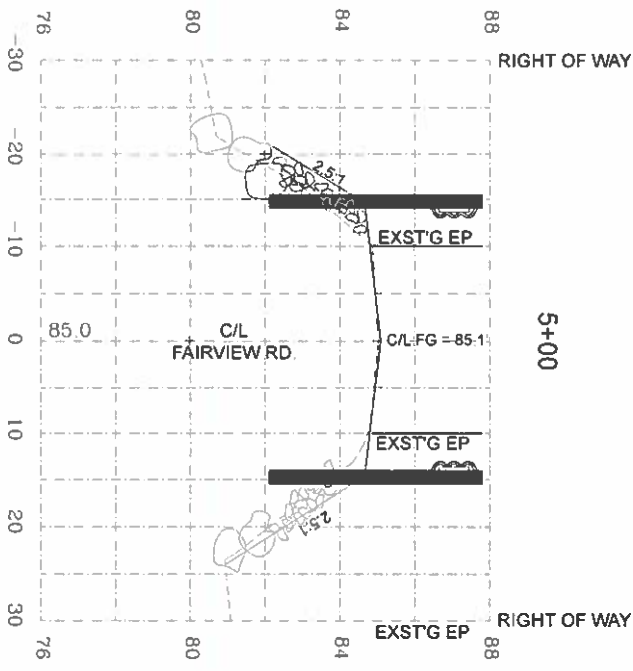
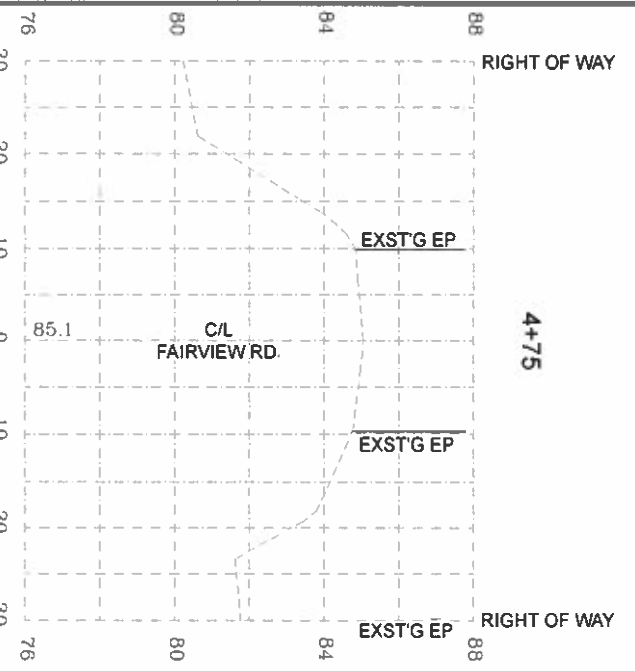
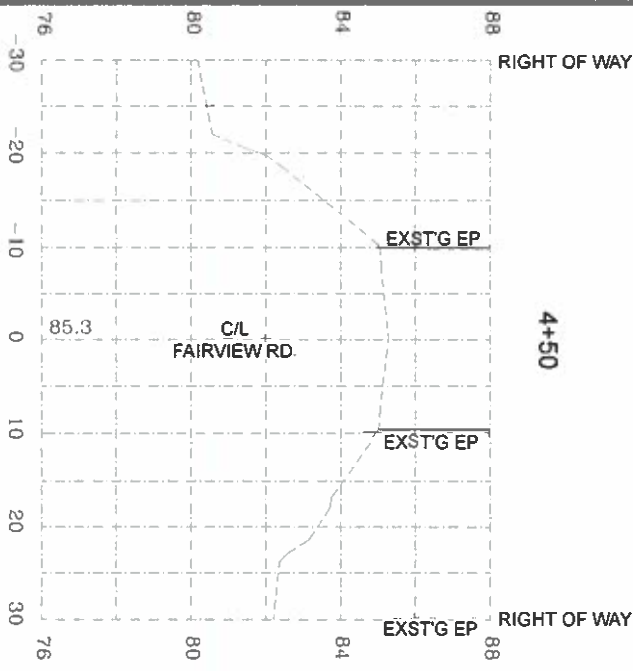

NOTE:
ALL BUTTRESS ROCK TO
BE IMBEDDED 12" AT BASE (TYP)
ALL BUTTRESS ROCK TO BE
ABOVE OHW

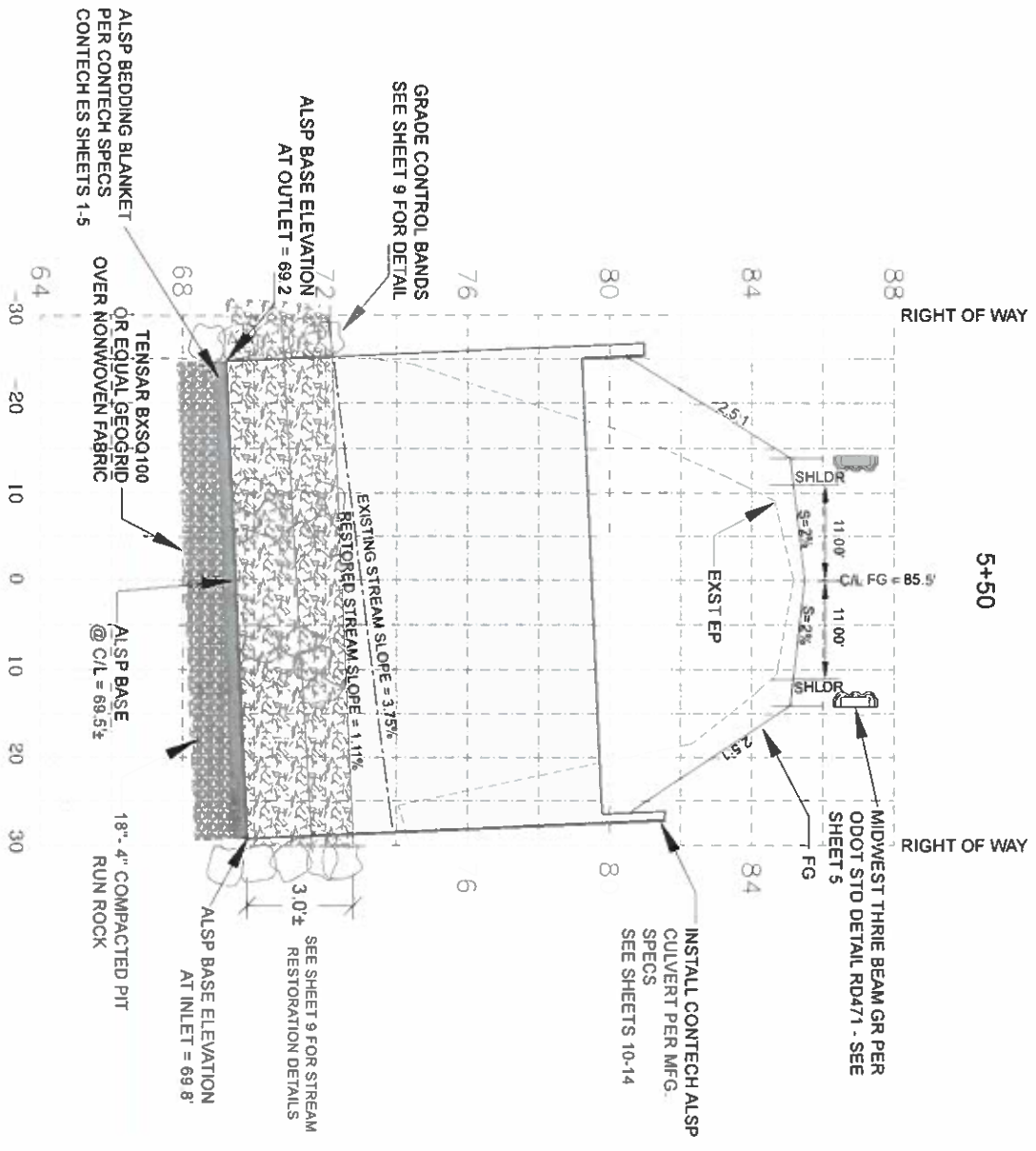

HORIZONTAL SCALE: 1" = 20'
VERTICAL SCALE: 1" = 4'
BAR SCALE MEASURES 2"

SHEET 6 OF 9
JOB NUMBER 22.0761.161

HUGHEY CREEK CULVERT TILLAMOOK, OREGON
ALUMINUM STRUCTURAL PLATE (ALSP) CULVERT REPLACEMENT
ROAD SECTIONS W/DETAIL

DESIGNATION	NO.	DATE	DESCRIPTION	BY
DESIGN	2	05-05-23	SUBMIT FOR AGENCY PRELIMINARY REVIEW	REN
DRN. REN	1	02-28-23	EDITS TO SUPPORT AGENCY COMMENTS	REN
CKD. CTL	NO.	DATE	DESCRIPTION	BY
DATE:	JAN 23			



REGISTERED PROFESSIONAL ENGINEER
92764PE
OREGON
6-29-23
SEPT. 12, 2017
CHRISTOPH T. LAITY
EXPIRES: 12/31/2024

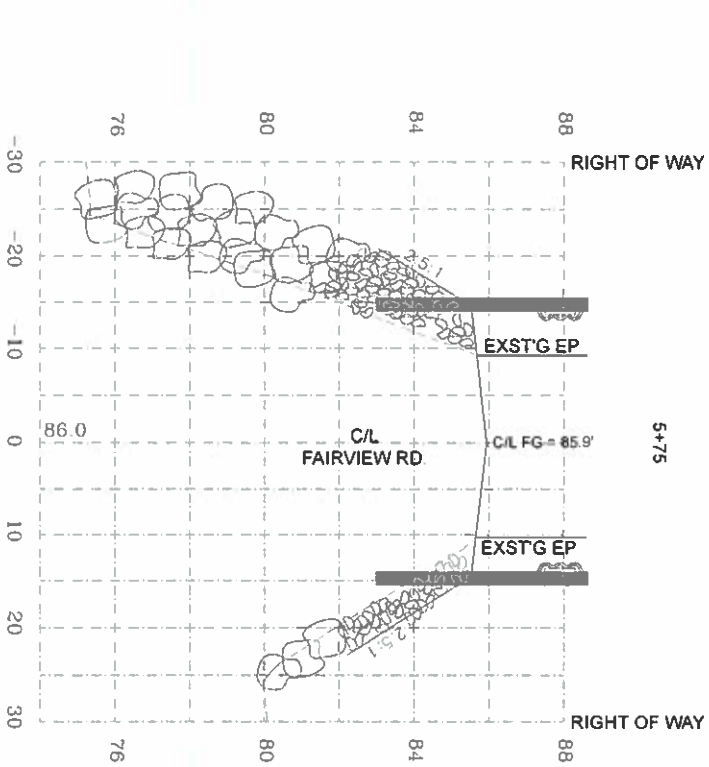

NOTE:
ALL BUTTRESS ROCK TO
BE IMBEDDED 12" AT BASE (TYP)
ALL BUTTRESS ROCK TO BE
ABOVE OHW

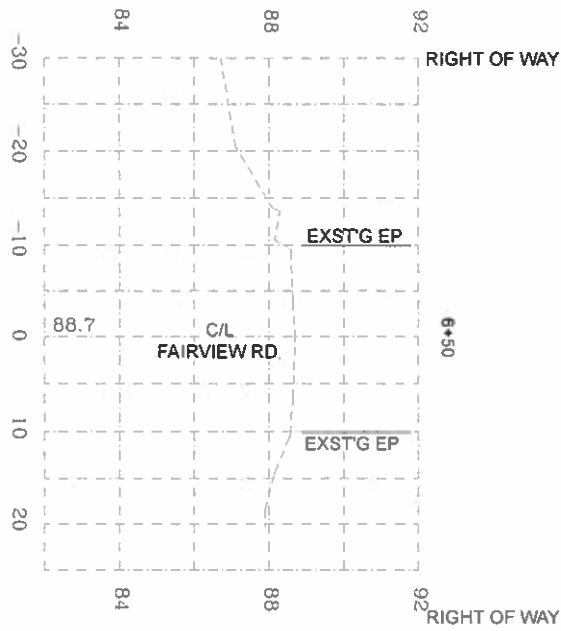
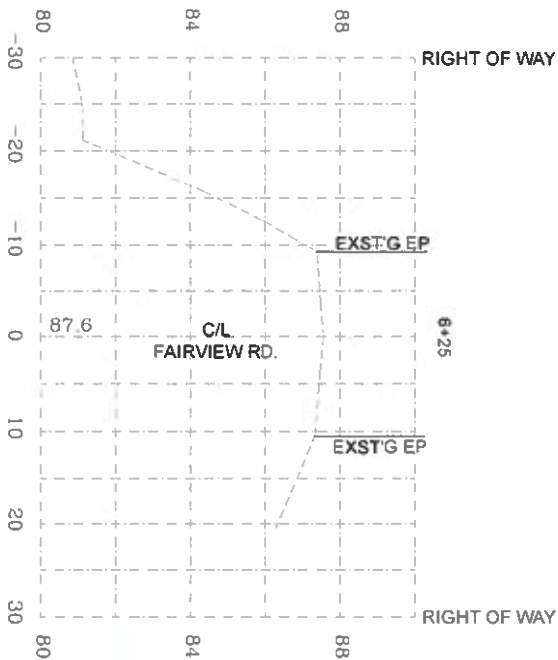
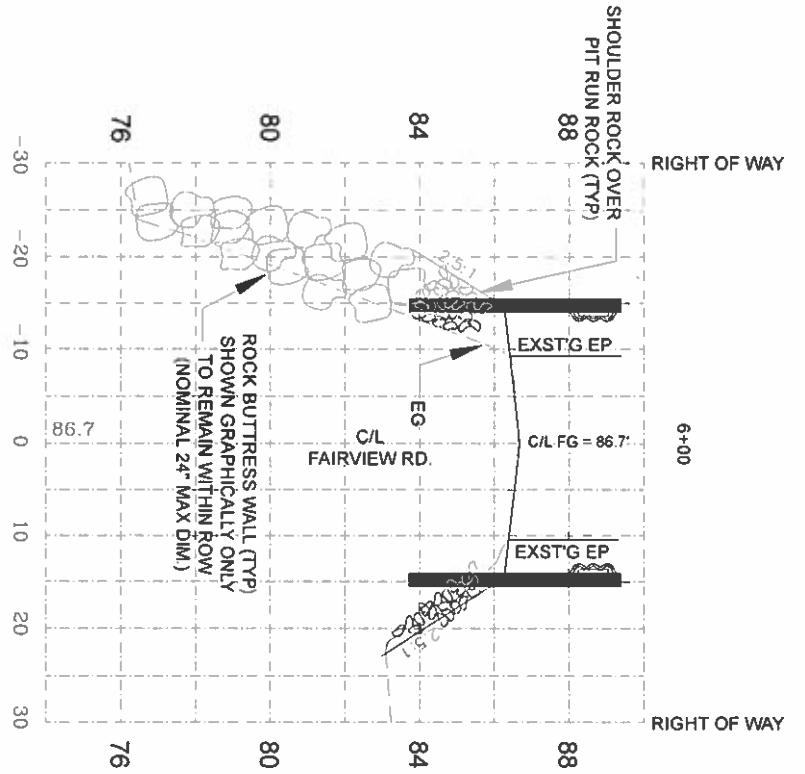

HORIZONTAL SCALE: 1" = 20'
VERTICAL SCALE: 1" = 4'
BAR SCALE MEASURES 2"

JOB NUMBER
22.0761.161

HUGHEY CREEK CULVERT TILLAMOOK, OREGON
ALUMINUM STRUCTURAL PLATE (ALSP) CULVERT REPLACEMENT

ROAD SECTIONS W/DETAIL

NO.	DATE	DESCRIPTION	BY
DESN REN 2	05-05-23	SUBMIT FOR AGENCY PRELIMINARY REVIEW	REN
DRN REN 1	02-28-23	EDITS TO SUPPORT AGENCY COMMENTS	REN
CKD CTL			
DATE: JAN '23			

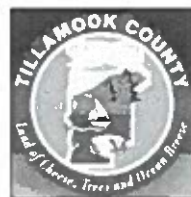

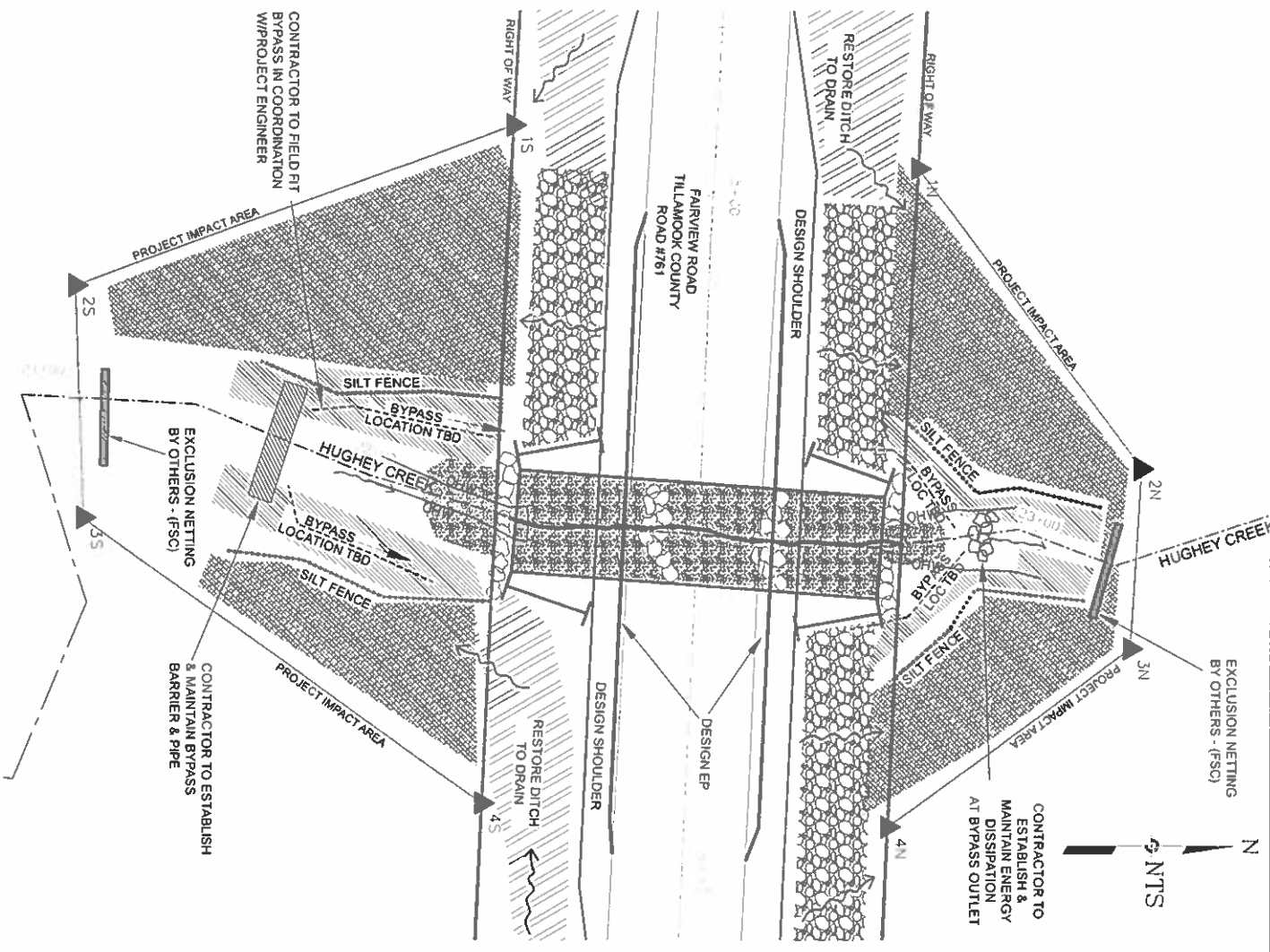

PROJECT IMPACT AREA	
PNT NO	NORTHING
1N	671876.682
2N	671909.746
3N	671908.061
4N	671872.224
1S	671816.933
2S	671752.359
3S	671753.496
4S	671812.323

STREAM STAYS STORM FLOW ESTIMATES: CFS	
YEAR	ESTIMATE
2 YEAR	90
5 YEAR	131
10 YEAR	180
25 YEAR	198
100 YEAR	257

- PROJECT STORMWATER NOTES:**
- 1) SEQUENCE CLEARING & GRADING TO THE MAXIMUM EXTENT PRACTICAL TO PREVENT EXPOSED INACTIVE AREAS FROM BECOMING A SOURCE OF EROSION.
 - 2) CREATE SMOOTH SURFACES BETWEEN SOIL SURFACE & EROSION & SEDIMENT CONTROLS TO PREVENT STORMWATER FROM BYPASSING CONTROLS.
 - 3) IDENTIFY, MARK & PROTECT CRITICAL RIPARIAN AREAS WITH SEDIMENT FENCING.
 - 4) PRESERVE EXISTING VEGETATION WHEN PRACTICAL & RE-VEGETATE OPEN AREAS AFTER CONSTRUCTION.
 - 5) INSTALL PERIMETER SEDIMENT CONTROL SILT FENCE TO CONTROL EROSION IN DISTURBED AREAS PER ODOT DETAIL #RD1040. (NOT PROVIDED).
 - 6) PLACE COCONUT OR STRAW WATTLES PERPENDICULAR TO SLOPES IN ALL DISTURBED AREAS.
 - 7) CONTROL SEDIMENT AS NEEDED ALONG THE SITE PERIMETER AND AT ALL LOCATIONS OF DISTURBED SOILS.
 - 8) PREVENT TRACKING OF SEDIMENT ONTO THE PUBLIC ROADWAY AND ADJACENT PRIVATE LAND.
 - 9) ENSURE THAT STEEP SLOPE AREAS ARE NOT DISTURBED. DISTURBED SLOPES ARE TO BE STABILIZED PER ODOT DETAIL #RD1032. (NOT PROVIDED)
 - 10) USE APPROPRIATE BMP'S TO PREVENT STORMWATER EXPOSURE TO SPILLS FROM FUELING, CLEANING, STORING, ETC. OF SOLVENTS, FUELS AND OTHER OILS.
 - 11) ALL SOIL STOCK PILES ARE TO BE STABILIZED OR COVERED AT THE END OF EACH WORK DAY.
 - 12) REMOVE TRAPPED SEDIMENT FROM BEHIND SEDIMENT FENCING BEFORE IT REACHES ONE THIRD OF THE ABOVE GROUND FENCE HEIGHT. FOR OTHER SEDIMENT BARRIERS, REMOVE SEDIMENT BEFORE IT REACHES TWO INCHES DEPTH AND REMOVE SEDIMENT BEFORE BMP REMOVAL.
 - 13) WITHIN 24 HOURS, SIGNIFICANT SEDIMENT THAT HAS LEFT THE SITE MUST BE REMEDIATED AND THE CAUSE CORRECTED.
 - 14) THE INTENTIONAL WASHING OF SEDIMENT INTO THE ACTIVE STREAM IS EXPLICITLY PROHIBITED.
 - 15) TEMPORARY STABILIZATION BMP'S ARE TO BE REMOVED IF CONSTRUCTION ACTIVITY STOPS FOR 14 DAYS. DISTURBED GROUND SHALL BE COVERED WITH BLOWN STRAW OR COMPOST UNTIL WORK RESUMES.
 - 16) DO NOT REMOVE TEMPORARY BMP'S UNTIL PERMANENT VEGETATION OF EXPOSED AREAS IS ESTABLISHED.

SURFACE RESTORATION LEGEND

- BUFFER ABOVE OHW
- PASTURE GRASS
- ROADSIDE GRASS
- OHW BUFFER TO BE SMALL WOODY SPECIES: BLACK TWIMBERY, RED-OSIER DOGWOOD, PACIFIC NINEBARK, ETC. W/ BIG LEAF MAPLE SPACED TO CREATE SHADE COVER
- FOLLOW RANDOM PLANTING PATTERN PER ODOT DETAIL - #DET6105 (NOT PROVIDED)
- ALL GRASS SEED TO BE STERILE AND CERTIFIED WEED FREE NATIVE SOURCE

FISH SALVAGE COORDINATOR - (FSC)
 Tillamook Bay Estuary Partnership
 Conrad Ely, Habitat Restoration
 Project Manager
 Office: 503-457-4114
 Conrad@TBNEP.org

GENERAL STREAM ISOLATION & ESC NOTES:

- 1) THIS PLAN IS FOR GUIDANCE ONLY. CONTRACTOR TO PROVIDE ISOLATION & ESC PLANS TO OWNER PRIOR TO COMMENCEMENT OF WORK. WRITTEN APPROVAL REQUIRED
- 2) FINAL LOCATION OF STREAM ISOLATION DAM & BYPASS TO BE FIELD FIT AS APPROVED BY PROJECT ENGINEER IN COORDINATION WITH FISH SALVAGE COORDINATOR
- 3) CONTRACTOR TO PROVIDE ALL PUMPS, PIPE, MISC. MATERIALS & LABOR REQUIRED TO ESTABLISH & MAINTAIN STREAM BYPASS SYSTEM
- 4) CONTRACTOR TO PROVIDE AND MAINTAIN SPILL KIT AND SPILL PREVENTION PROCEDURES INCLUDING STAFF TRAINING, SPILL PREVENTION TO INCLUDE STORING AND FUELING OF EQUIPMENT A MINIMUM OF 50' FROM AREAS OF OPEN EXCAVATION
- 5) ALL STOCK PILED MATERIALS SHALL BE COVERED AT END OF SHIFT AND END OF WEEK. CONTRACTOR TO PLACE PERIMETER COIR WATTLES OR OTHER BMP AS NECESSARY TO ELIMINATE MATERIAL WASHOUT
- 6) FISH ISOLATION NETS TO BE PROVIDED & PLACED THROUGH COORDINATION WITH FAISH SALVAGE COORDINATOR.
- 7) FISH SALVAGE & RELEASE SCHEDULE TO BE COORDINATED THROUGH FISH SALVAGE COORDINATOR AND COMPLETED BY OTHERS.
- 8) STREAM BED ISOLATION IS INTENDED TO ACHIEVE DRY STREAM BED CONDITION AS CLOSE AS PRACTICAL PRIOR TO EXCAVATION
- 9) CONTRACTOR TO PLACE ADDITIONAL BMP'S AS CONDITIONS MAY REQUIRE TO LIMIT SEDIMENTATION INTO DOWNSTREAM HUGHEY CREEK TO DEC 1200-C LEVELS
- 10) VEGETATION REESTABLISHMENT TO BE COMPLETED BY OWNER

ODOT DETAILS REFERENCED	
DETAIL NO	TYPE & SEDIMENT BARRIER
RD1032	TYPE 8 SEDIMENT BARRIER
RD1040	SEDIMENT FENCE DETAIL
DET6105	PLANTING PATTERN DETAIL



NO.	DATE	DESCRIPTION	BY
2	05-05-23	SUBMIT FOR AGENCY PRELIMINARY REVIEW	REN
1	02-28-23	EDITS TO SUPPORT AGENCY COMMENTS	REN
NO.	DATE	DESCRIPTION	BY
DESIGN	REN		
DATE	JAN '23		

HUGHEY CREEK CULVERT TILLAMOOK, OREGON
 ALUMINUM STRUCTURAL PLATE (ALSP) CULVERT REPLACEMENT
STREAM ISOLATION & EROSION CONTROL PLAN

SHEET 8 OF 14
 JOB NUMBER 22.0761.161

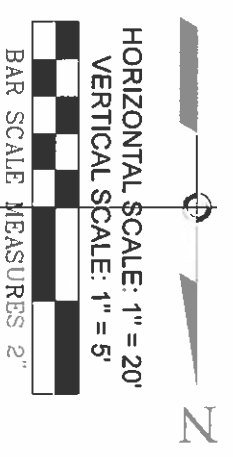
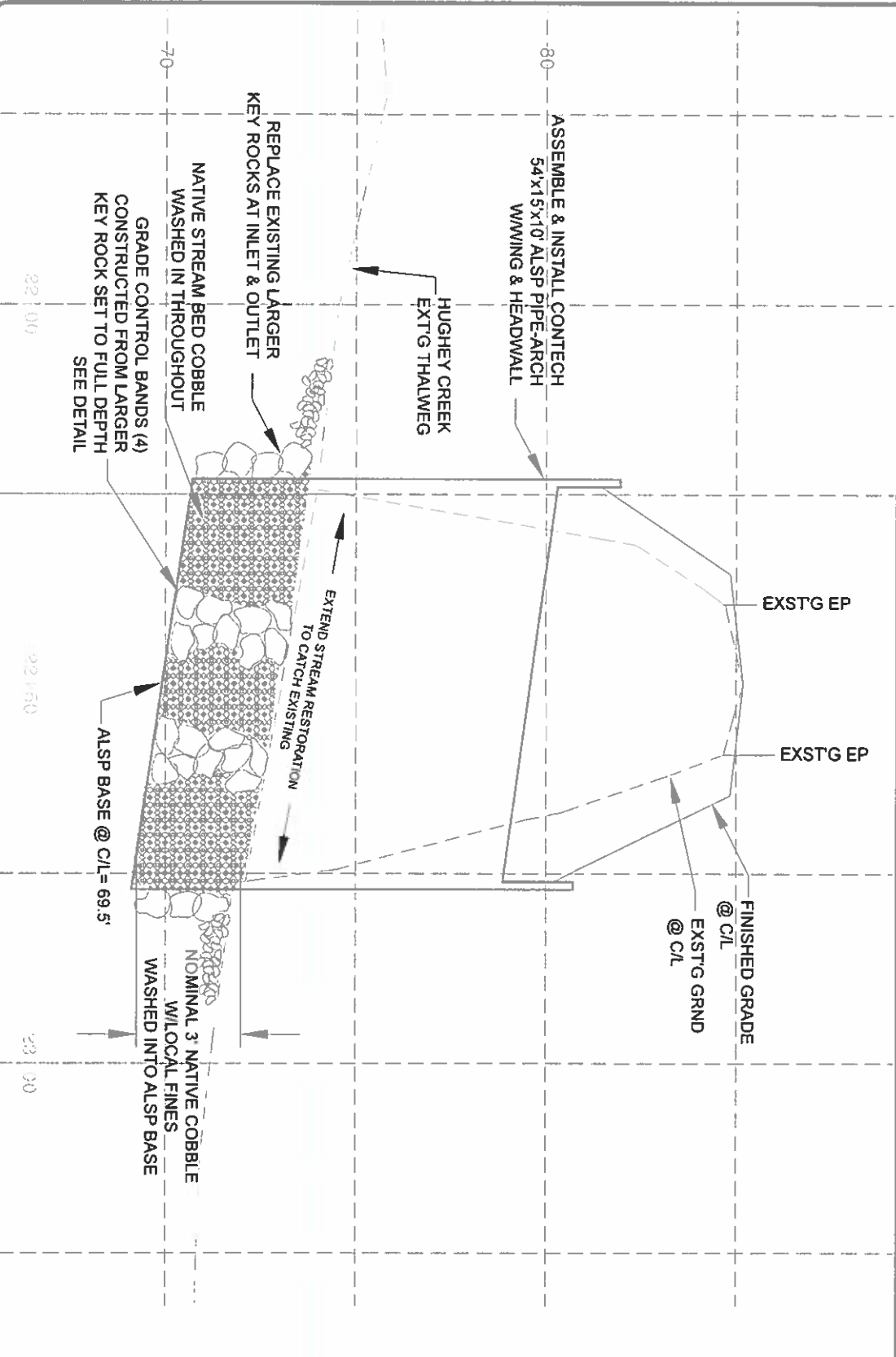
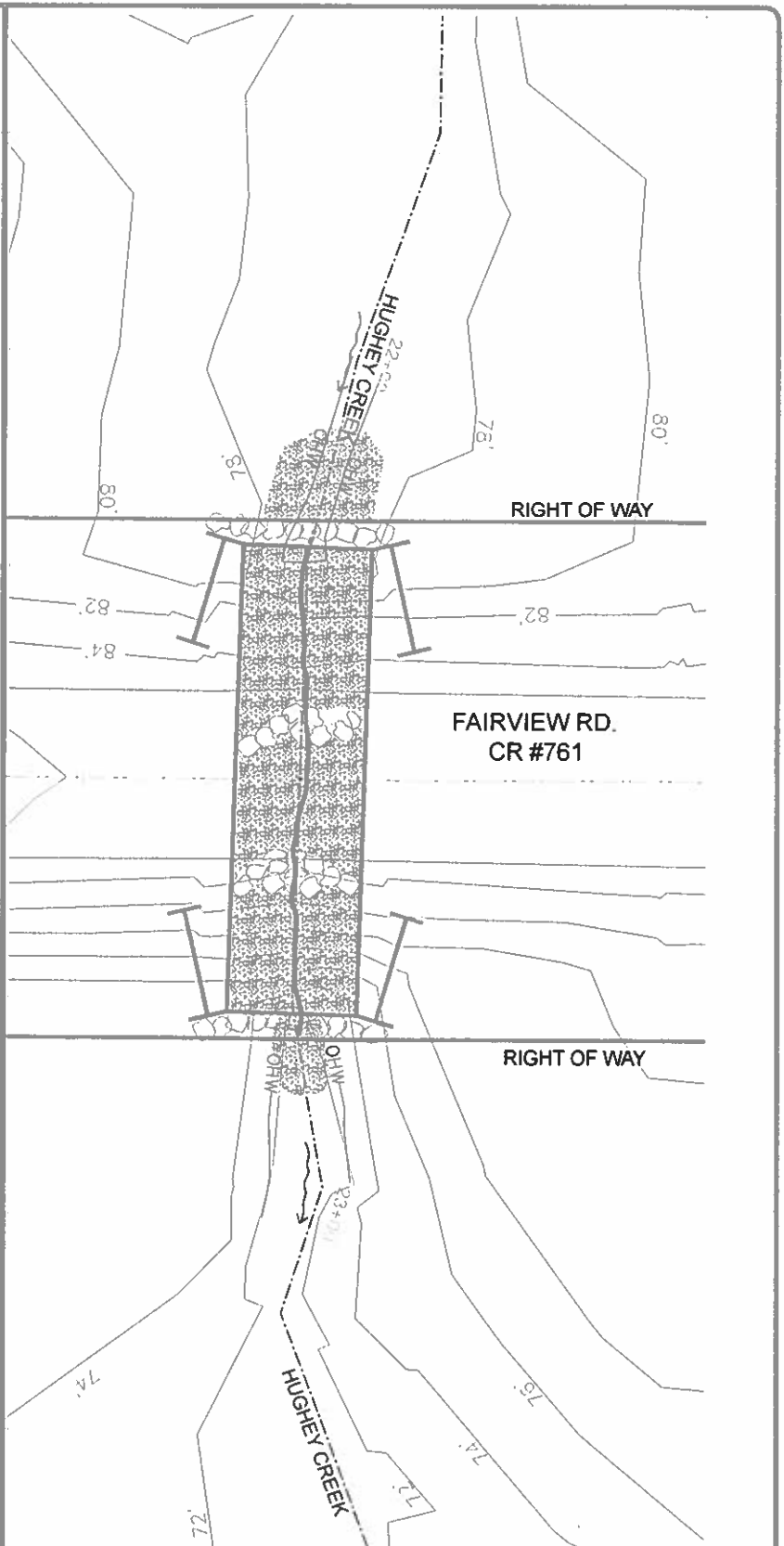

- GENERAL STREAM RESTORATION NOTES:**
- 1) CONTRACTOR TO SALVAGE & STOCKPILE NATIVE STREAM BED MATERIAL DURING EXCAVATION
 - 2) NATIVE STREAM BED MATERIAL TO BE PLACED & GRADED THROUGHOUT REPLACEMENT CULVERT
 - 3) GRADE CONTROL BANDS TO BE NOMINAL 18" BOULDERS
 - 4) STREAM FLOW LINE DROP ACROSS GRADE CONTROL BANDS NOT TO EXCEED 6"
 - 5) INLET & OUTLET GRADING TO BE ADJUSTED TO FIT GRADES AT THE FACE OF NEW CULVERT HEADWALLS
 - 6) STREAM GRADING TO FIT ADJACENT EXISTING RESTORED THALWEG TO FOLLOW LOW FLOW CHANNEL THROUGH GRADE CONTROL BANDS

GRADE CONTROL BAND REFERENCE DATA:

STA.	DESCRIPTION	BAND CREST ELEV. FT.	OHW
22+25	UPSTREAM HEADWALL	72.8	73.9
22+40	UPSTREAM INTERNAL	73.2	73.8
22+60	DOWNSTREAM INTERNAL	72.7	73.6
22+70	DOWNSTREAM HEADWALL	72.2	73.4
22+50	100 YR STORM WSE - (CULVERT MID-POINT)	75.7	75.7

GRADE CONTROL BANDS TO BE CONSTRUCTED W/SELECT QUARRY KEY ROCK NOMINAL 18" MAXIMUM DIMENSION

HUGHEY CREEK
ACW = 8' - ODFW 2022

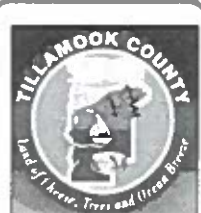
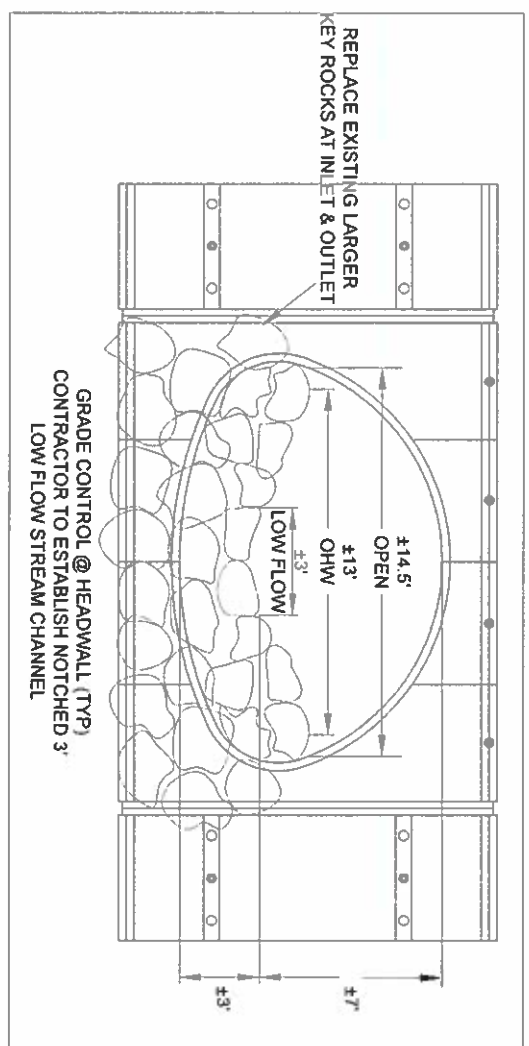
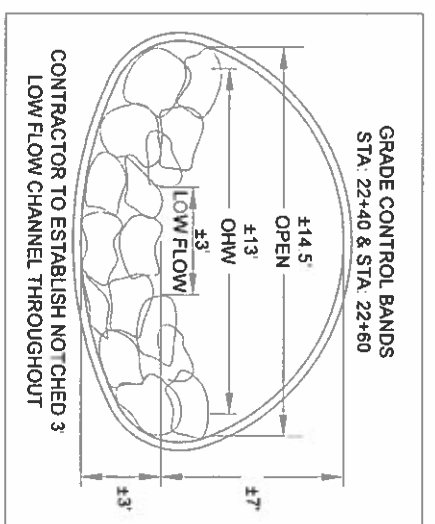

NO.	DATE	DESCRIPTION	BY
1	05-05-23	SUBMIT FOR AGENCY PRELIMINARY REVIEW	REN
2	22823	PRE-APP AGENCY REVIEW	REN
3			
4			
5			

HUGHEY CREEK CULVERT TILLAMOOK, OREGON
ALUMINUM STRUCTURAL PLATE (ALSP) CULVERT REPLACEMENT
STREAM RESTORATION PLAN

9 OF 9 SHEET
JOB NUMBER 22.0761.161

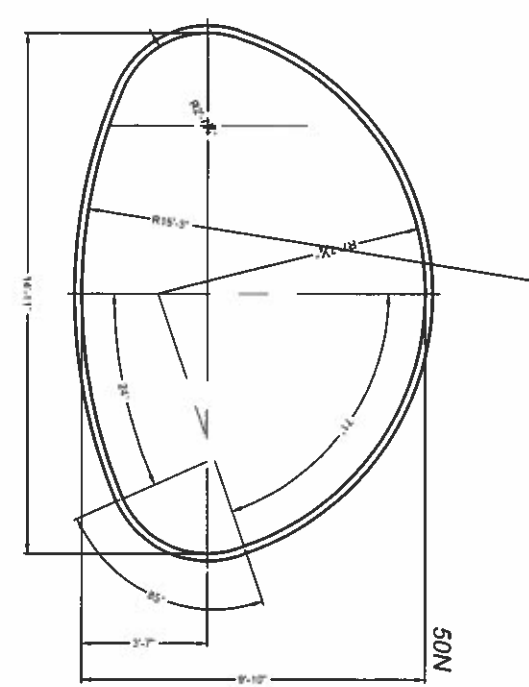
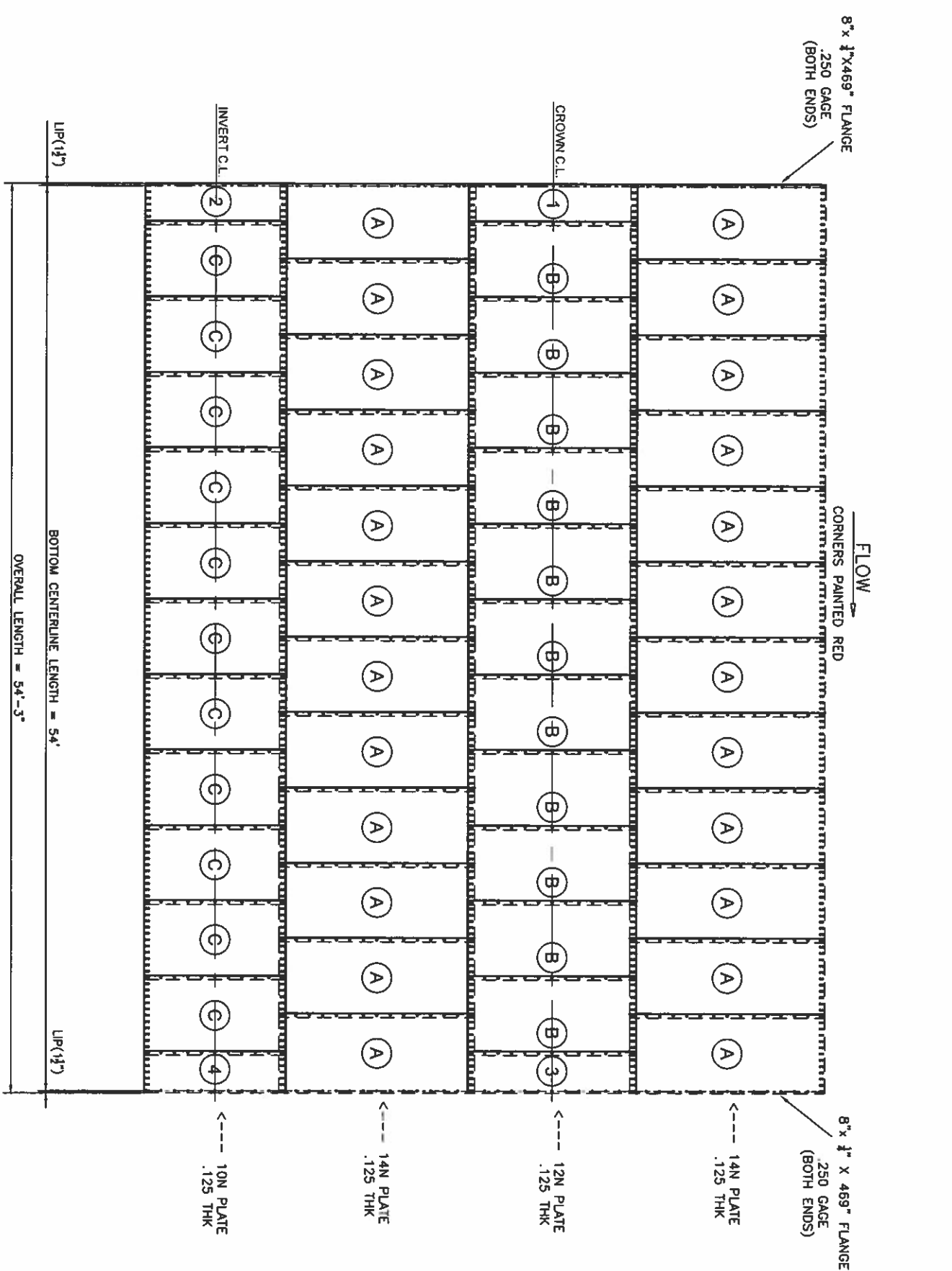

APPROX. AREA = 114.2 SQ. FT.

NOTES:

- 1) MEASUREMENTS ARE TO THE INSIDE CRESTS OF THE CORRUGATIONS.
- 2) DIMENSIONS ARE SUBJECT TO MANUFACTURING TOLERANCES.
- 3) CIRCUM. PLATE LENGTHS ARE IN TERMS OF N. (N=9.625" OR 3 PI).

GENERAL NOTES:

1. Continuation of cover - This structure is within the minimum and maximum allowable height of cover, for the designated loading, as follows:
Loading: HL-93, Minimum cover (ft) 3.0, Maximum cover (ft) 9.0
2. For proper bolt size usage, refer to following:
Plate only 2. plate lap 3. plate lap 4. plate lap
0.100" - 0.125" thk. plate 1-1/4" 1-1/4" 1-1/4"
0.150" - 0.200" thk. plate 1-1/4" 1-1/4" 1-1/4"
0.225" - 0.250" thk. plate 1-1/2" 1-1/2" 1-1/2"
With Reinforcing Rib (if used) 1. plate 2" 2" 2"
0.100" - 0.175" thk. plate 1-1/4" 1-1/2" 2"
0.200" - 0.250" thk. plate 1-1/2" 2" 2"
Occurs with full inverts only which have 0.100" thick plates.
3. Nuts may be located on structure's interior or exterior to allow conventional access during assembly and torquing. Only one side of nut has a curved surface and it should be in direct contact with plate valley.
4. All bolts and nuts should be properly torqued in accordance with a torque wrench using proper procedure. The sequence of torquing should be as follows: fasteners (finger tightened only); Before backfilling commences, all fasteners must be torqued for adequate component contact. Good component fit is better than high torque.
5. Fastener torque requirements: 0.100" thick plate of 90-115 foot-pounds. For all thicker plates and reinforcing ribs, torque at 115-135 foot-pounds. Torque levels are for installation, not residual, in-service requirements. Since torquing may loosen previously tightened fasteners, multiple passes may be necessary. When seam section tops is used, fasteners should be torqued again after 24 hours.
6. All aluminum structural plate material is manufactured in accordance with ASTM A5210 M219, ASTM B746 and ASTM B666 specifications.
7. See ASSEMBLY INSTRUCTIONS shipped with material in fastener container. Also refer to specific product catalog for additional product information.

THE ASSEMBLY BOLTS AND NUTS ARE SPECIALLY DESIGNED WITH ROUNDED OR SPHERICAL THROATS FOR FITTING EITHER THE CREST OR VALLEY OF THE CORRUGATIONS, PROVIDING MAXIMUM BEARING CONTACT AREA WITH THE PLATES WITHOUT THE USE OF WASHERS. NOTE THAT THE BOLTS AND NUTS SHOULD BE INSTALLED SUCH THAT THE ROUNDED PORTION IS IN CONTACT WITH THE PLATES

INLET	OUTLET	TYPE STRUCTURE	PIPE ARCH
90	90	SIZE SON	14'-11"
		SPAN	14'-11"
		RISE	9'-10"
BEVEL	0	LENGTH	9.45'-0"

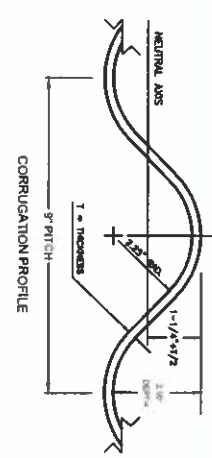

PLANT ORDER
No: 9634270

PROJECT NO.	698969	SEQ. NO.	010	DATE	6/13/2022
DESIGNED		DRAWN	JEM/ASR		
CHECKED		APPROVED			

CONTECH ENGINEERED SOLUTIONS LLC
700 Ted Drive, Winchester, KY 40391
859-744-3339 859-744-9685 FAX

CONTECH STRUCTURAL PLATE FABRICATION DRAWING

HUGHEY CREEK
TILLAMOOK, OR

PLANT ORDER NO. **9634270**
SALES ORDER NO.

DRAWING # **698969.10-ALSP-FAB-A**

MARK	DATE	REVISION DESCRIPTION	BY
1			

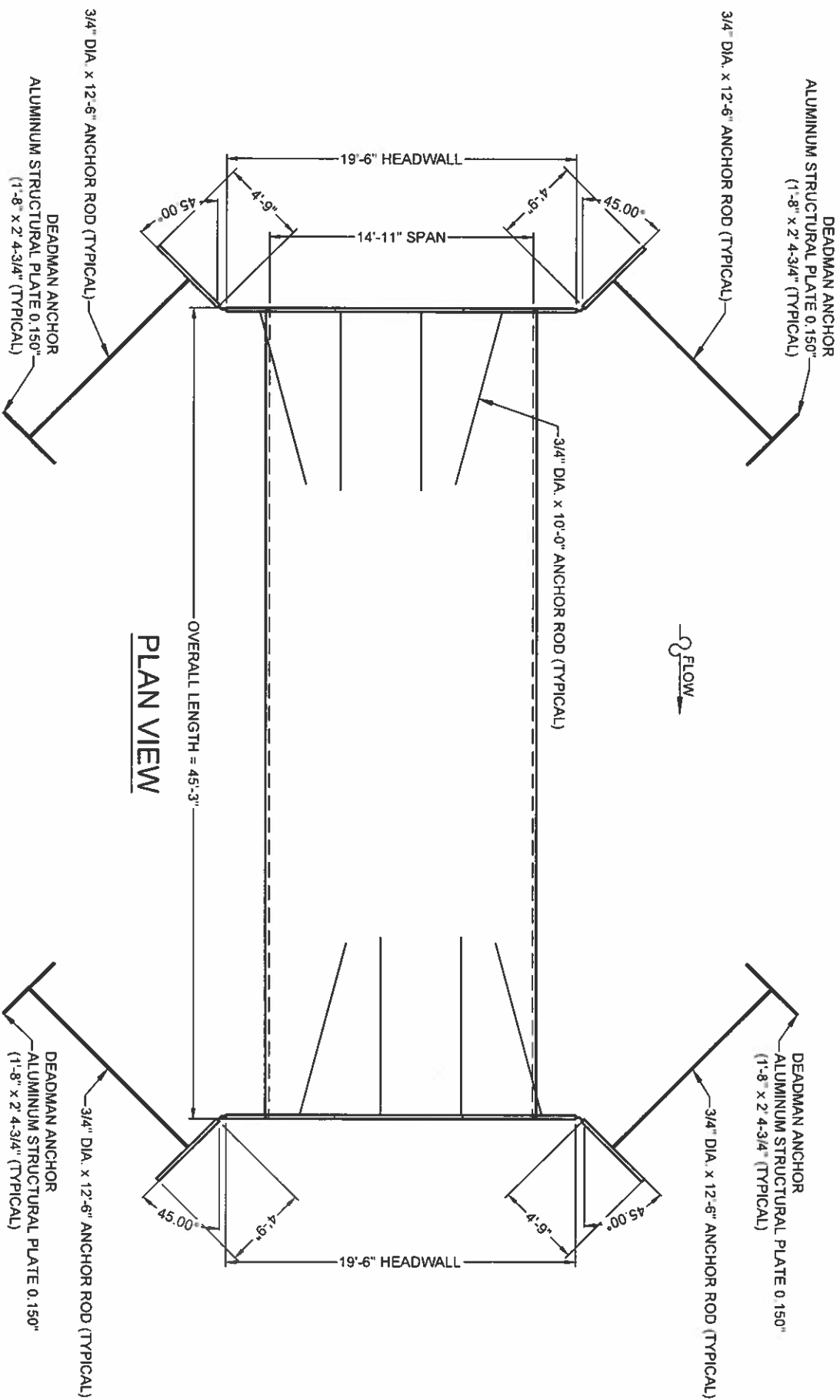

PLAN VIEW

INLET	OUTLET	TYPE	STRUCTURE
90	90	SIZE	SON
0	0	SPAN	= 14'-11"
		RISE	= 9'-10"
		BEVEL	0
		LENGTH	45'-0"

PLANT ORDER
No: 9634270

PLANT ORDER NO.
9634270

SALES ORDER NO.
9634270

THE ASSEMBLY BOLTS AND NUTS ARE SPECIALLY DESIGNED WITH ROUNDED OR SPHERICAL THROATS FOR FITTING EITHER THE CREST OR VALLEY OF THE CORRUGATIONS PROVIDING MAXIMUM BEARING CONTACT AREA WITH THE PLATES WITHOUT THE USE OF WASHERS. NOTE THAT THE BOLTS AND NUTS SHOULD BE INSTALLED SUCH THAT THE ROUNDED PORTION IS IN CONTACT WITH THE PLATES

The design and information shown on this drawing is provided as a service to the project owner, engineer and contractor by the design engineer. It is not to be used for any other purpose without the prior written consent of the design engineer. The design engineer shall not be held responsible for any errors or omissions in this drawing. The design engineer shall not be held responsible for any errors or omissions in this drawing. The design engineer shall not be held responsible for any errors or omissions in this drawing.

MARK	DATE	REVISION DESCRIPTION	BY

CONTECH
ENGINEERED SOLUTIONS LLC
www.conteches.com
700 Todd Drive, Winchester, KY 40391
859-744-3339 859-744-9865 FAX

CONTECH
STRUCTURAL PLATE
FABRICATION
DRAWING

HUGHEY CREEK
TILLAMOOK, OR

PROJECT NO.	698969	SEQ. NO.	010	DATE	6/13/2022
DESIGNED		DRAWN	JEM/ASR		
CHECKED		APPROVED			
SHEET NO.	2	OF	5		

- NOTES:
1. ALL MARK IDENTIFICATIONS TO BE ON SOIL SIDE.
 2. BOLT HEADWALL TO REINFORCING RIB AT END OF STRUCTURE.
 3. SEE SHEET 4 FOR SECTION AND ASSEMBLY DETAIL S.
 4. ALL 2'-3" DIMENSIONS ARE RELATIVE TO SECTION B-B.
 5. ALL 4 1/2" DIMENSIONS ARE RELATIVE TO SECTION E-E.
 6. DENOTES BOLTS
 7. DENOTES RODS

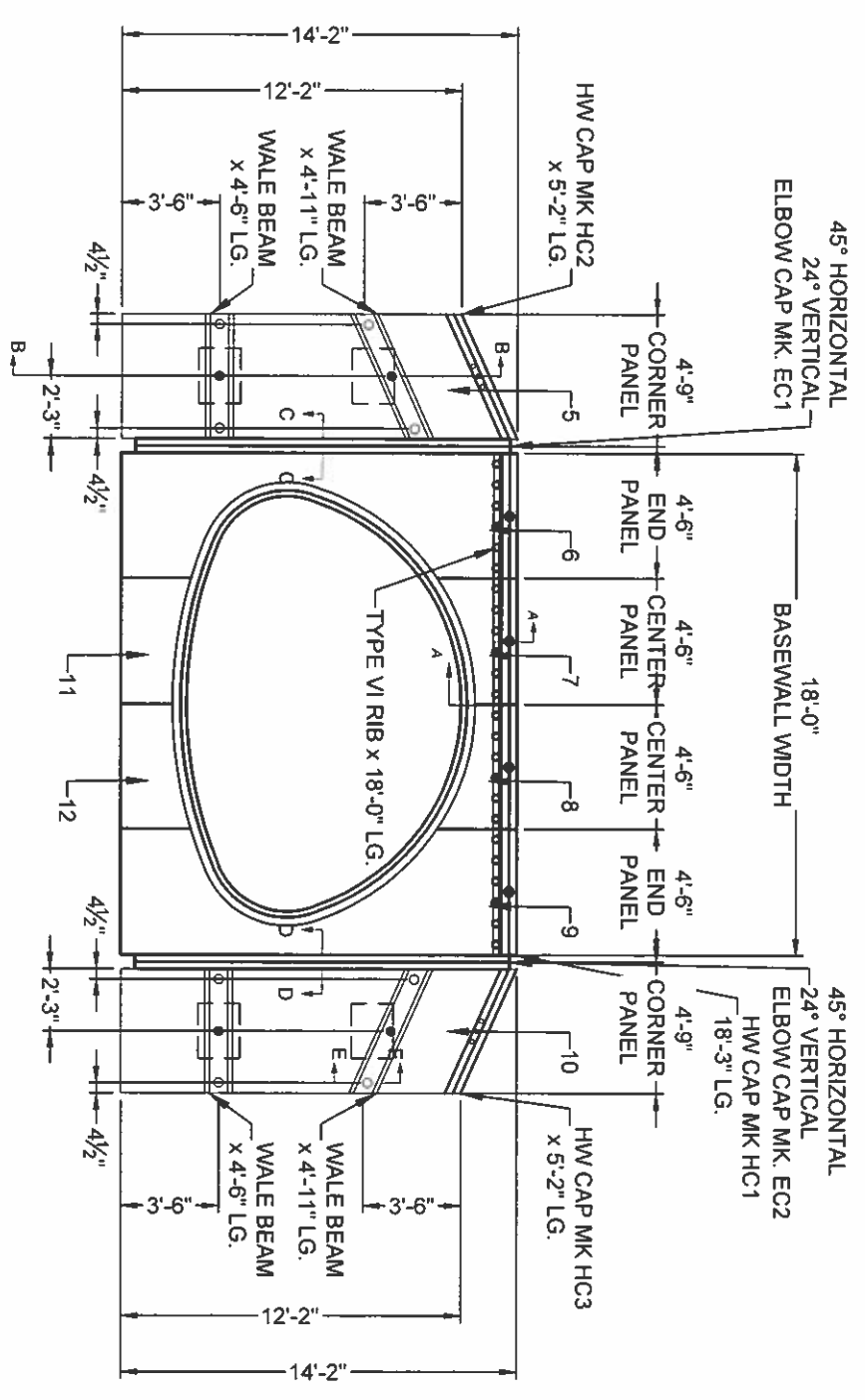

ALSP - INLET EXPANDED END VIEW

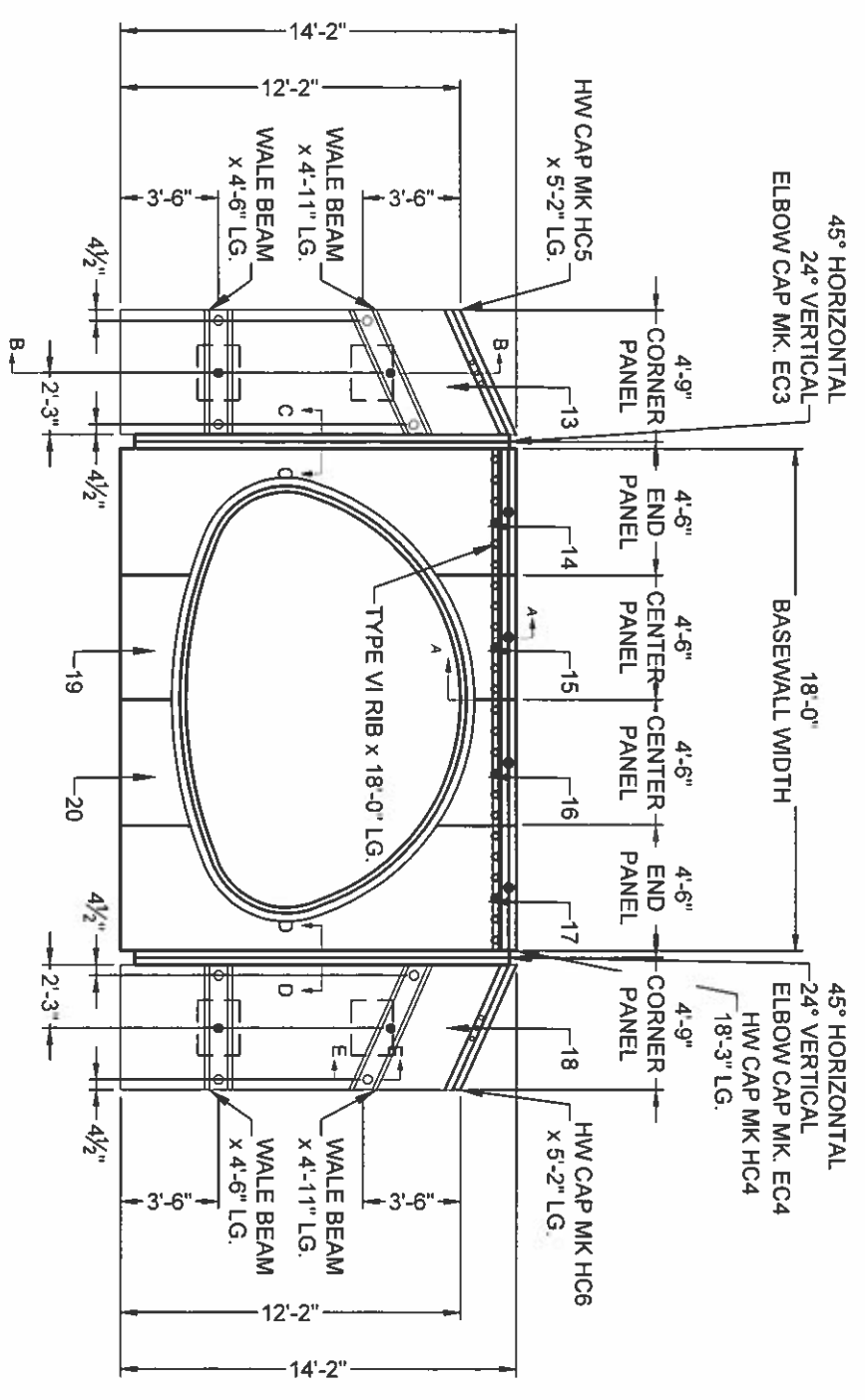

ALSP - OUTLET EXPANDED END VIEW

INLET	OUTLET	TYPE STRUCTURE	PIPE ARCH
SKEW 90	90	SIZE SON	14'-11"
		SPAN	9'-10"
		RISE	9'-10"
BEVEL 0	0	LENGTH	9.45'-0"

PLANT ORDER
No: 9634270

PROJECT NO.	698969	SEQ. NO.	010	DATE	6/13/2022
DESIGNED		DRAWN	JEM/ASR		
CHECKED		APPROVED			
SHEET NO.	3	OF	5		

PLANT ORDER NO. 9634270
SALES ORDER NO. 9634270

THE ASSEMBLY BOLTS AND NUTS ARE SPECIALLY DESIGNED WITH ROUNDED OR SPHERICAL THROATS FOR FITTING EITHER THE CREST OR VALLEY OF THE CORRUGATIONS, PROVIDING MAXIMUM BEARING CONTACT AREA WITH THE PLATES WITHOUT THE USE OF WASHERS. NOTE THAT THE BOLTS AND NUTS SHOULD BE INSTALLED SUCH THAT THE ROUNDED PORTION IS IN CONTACT WITH THE PLATES.

The design and information shown on this drawing is provided as a service to the project owner, engineer and contractor by Contech Engineered Solutions LLC ("Contech"). Neither Contech nor its employees, agents, or contractors warrant, represent, or make any statement about the accuracy, completeness, or reliability of any information or data provided by the project owner, engineer, or contractor. Contech expressly disclaims any liability or responsibility for any damages, including consequential damages, arising from the use of this drawing. Contech is not responsible for any errors or omissions in this drawing. Contech is not responsible for any damages, including consequential damages, arising from the use of this drawing. Contech is not responsible for any damages, including consequential damages, arising from the use of this drawing.

CONTECH
ENGINEERED SOLUTIONS LLC
www.conteches.com
700 Ted Drive, Winchester, KY 40391
859-744-3339 859-744-9665 FAX

CONTECH
STRUCTURAL PLATE
FABRICATION
DRAWING

HUGHEY CREEK
TILLAMOOK, OR

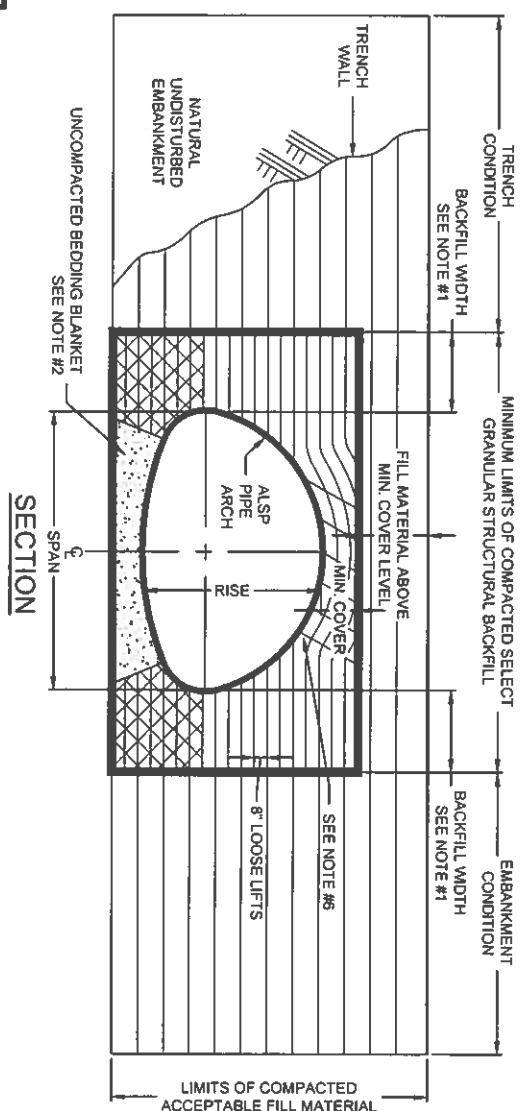

- NOTES:
- TRENCH WIDTH AND/OR SELECT BACKFILL WIDTH SHALL BE DETERMINED BY THE ENGINEER OF RECORD DEPENDING ON SITE SPECIFIC CONDITIONS. TYPICAL BACKFILL WIDTH IS 3 FEET FOR STRUC TO BE SPANS 14 FEET AND LESS, AND 8 FEET FOR STRUCTURE SPANS GREATER THAN 14 FEET.
 - THE MINIMUM BEDDING THICKNESS SHALL BE 8 INCHES.
 - ALL SELECT GRANULAR BACKFILL TO BE PLACED IN A BALANCED FASHION IN THIN LIFTS, 8\"/>

ADDITIONAL SELECT GRANULAR STRUCTURAL BACKFILL NOTES:

SATISFACTORY BACKFILL MATERIAL, PROPER PLACEMENT, AND COMPACTION ARE KEY FACTORS IN OBTAINING MAXIMUM STRENGTH AND STABILITY.

THE BACKFILL MATERIAL SHOULD BE FREE OF ROCKS, FROZEN LUMPS, AND FOREIGN MATERIAL THAT COULD CAUSE HARD SPOTS OR DECOMPOSE TO CREATE VOIDS. BACKFILL MATERIAL SHOULD BE WELL GRADED GRANULAR MATERIAL THAT MEETS THE REQUIREMENTS OF AASHTO M-145 FOR SOIL CLASSIFICATIONS A-1, A-2-4, A-2-5 OR A-3 MODIFIED. SEE THE STRUCTURAL PLATE BACKFILL GROUP CLASSIFICATION TABLE ON THIS SHEET. BACKFILL MUST BE PLACED SYMMETRICALLY ON EACH SIDE OF THE STRUCTURE IN 8\"/>

GROUP CLASSIFICATION	A-1-4	A-1-6	A-2-4	A-2-5	A-3
Group Designation	—	—	—	—	—
No. 10 (2,000 mm)	88 max.	—	—	—	—
No. 40 (1,000 mm)	38 max.	50 max.	—	—	51 max.
No. 200 (0.075 mm)	18 max.	25 max.	35 max.	35 max.	10 max.

Attesting Limits for Friction Passing No. 40 (1,000 mm)

Liquid Limit	—	40 max.	41 min.
Plasticity Index	4 max.	6 max.	10 max.

Usual Materials: Stone Fragment, Gravel and Sand; Slity of Clay; Gravel and Sand; Coarse Sand

Modified from AASHTO M-145.

Fine beach sands, winddown sands, stream deposited sands, etc. exhibiting fine, rounded particles and typically classified by AASHTO M-145 as A-3 Materials should not be used.

Reference the most current version of ASTM D2487, Standard Practice for Classification of Soils for Engineering Purposes (Unified Soil Classification System), for comparable soil groups.

INLET	OUTLET	TYPE STRUCTURE	PIPE ARCH
80	90	SIZE 50N	
		SPAN = 14'-11"	
		RISE = 9'-10"	
BEVEL	0	LENGTH = 9.45'-0"	

PLANT ORDER
No: 9634270

DATE: _____
REVISION DESCRIPTION: _____

CONTECH
ENGINEERED SOLUTIONS LLC
www.conteches.com
700 Tech Drive, Winchester, KY 40391
859-744-3339 859-744-9665 FAX

CONTECH
STRUCTURAL PLATE
FABRICATION
DRAWING

HUGHEY CREEK
TILLAMOOK, OR

PLANT ORDER NO.
9634270
SALES ORDER NO.

PROJECT NO.	698969	SEQ. NO.	010	DATE	6/13/2022
DESIGNED		DRAWN	JEM/ASR	CHECKED	
SHEET NO.	5	OF	5		

THE ASSEMBLY BOLTS AND NUTS ARE SPECIALLY DESIGNED WITH ROUNDED SPHERICAL TROUSERS FOR FITTING EITHER THE CREST OR VALLEY OF THE CURVE. THE BOLTS AND NUTS ARE TO BE INSTALLED WITH THE PLATES WITHOUT THE USE OF WASHERS. NOTE THAT THE BOLTS AND NUTS SHOULD BE INSTALLED SUCH THAT THE ROUNDED PORTION IS IN CONTACT WITH THE PLATES.

- STANDARDS AND DEFINITIONS
 - STANDARDS - All standards refer to the current ASTM/AASHTO edition unless otherwise noted.
 - ASTM B746 - Casted Aluminum Alloy for Structural Plate for Field-Bolted Pipe, Pipe-Archies, and Arches. (AASHTO Designation M-219)
 - AASHTO Standard Specification for Highway Bridges - Section 12 Division I - Design. AASHTO LRFD Bridge Design Specifications Section 12
 - AASHTO Standard Specification for Highway Bridges - Section 26 Division II - Construction. AASHTO LRFD Bridge Construction Specifications - Section 26, ASTM B788 Standard Practice for Installing Corrugated Aluminum Structural Plate Pipe.
 - Manufacturer - In these specifications the word "Manufacturer" shall mean CONTECH ENGINEERED SOLUTIONS 800-338-1122 Madison House.
 - Contractor - In these specifications the word "Contractor" shall mean the firm or corporation undertaking the execution of any installation work under the terms of these specifications.
 - Approved - In these specifications the word "approved" shall refer to the approval of the Engineer or his designated representative.
 - As Directed - In these specifications the words "as directed" shall refer to the directions to the Contractor from the Owner or his designated representative.
- GENERAL CONDITIONS
 - Any installation guidance provided herein shall be endorsed by the Engineer, discrepancies herein are governed by the Engineer's plans and specifications.
 - The Contractor shall furnish all labor, material and equipment and perform all work and services except those set out and furnished by the Owner, necessary to complete in a satisfactory manner the site preparation, excavation, filling, compaction, grading as shown on the plans and as described therein. This work shall consist of all mobilization, clearing and grading, grubbing, stripping, removal of existing material unless otherwise stated, preparation of the fill and fill, filling of the land, spreading and compaction of the fill and all subsidiary work necessary to complete the grading of the cut and fill areas to conform with the lines, grades, slopes, and specifications. This work is to be accomplished under the observation of the Owner or his designated representative.
 - If an aluminum handrail and/or wingwall system is specified, the select granular structural backfill limits shall extend past the deadman anchor system, contact the Engineer if steel material or rock is encountered where the wingwalls and deadmen are to be installed.
 - Normal highway traffic is not allowed to cross the structure until the structure has been backfilled and paved. If the road is unpaved, cover allowance to accommodate rolling shall be as directed by the Engineer.
 - The structure shall be backfilled using clean well graded granular material that meets the requirements for soil classifications A-1, A-2-4, A-2-5 or A-3 modified per AASHTO M-145. See the structural plate backfill group classification table on this sheet. Backfill must be placed symmetrically on each side of the structure in 8 inch loose lifts. Each lift shall be compacted to a minimum of 80 percent density per AASHTO T-180.
 - If temporary construction vehicles are required to cross the structure, it is the Contractor's responsibility to contact the Engineer to determine the amount of additional minimum cover necessary to handle the specific loading condition.
- ASSEMBLY AND INSTALLATION
 - Bolts and nuts shall conform to the requirements of ASTM A307 and/or ASTM A449. The pipe arch structure shall be assembled in accordance with the plate layout drawings provided by the Manufacturer and per the Manufacturer's recommendations. Bolts shall be tightened using an applied torque of between 100 and 150 ft.-lbs.
 - The pipe arch structure shall be installed in accordance with the plans and specifications, the Manufacturer's recommendations, and AASHTO Standard Specification for Highway Bridges - Section 26 Division II - Construction/AASHTO LRFD Bridge Construction Specifications - Section 26.
 - Trench excavation shall be made in embankment material that is structurally adequate. The trench width shall be shown on the plans. Poor quality in situ embankment material must be removed and replaced with suitable backfill as directed by the Engineer.
 - Bedding preparation is critical to both structure performance and service life. The bed should be constructed to uniform line and grade to avoid distortions that may create undesirable stresses in the structure and/or rapid deterioration of the roadway. The bed should be free of rock formations, protruding stones, frozen lumps, roots, and other foreign matter that may cause unequal settlement.
 - The foundation shall be designed to support the radial pressures exerted by the smaller radius portions of the pipe. The principal foundation support shall be provided in the critical haunch area extending radially outward from the haunches.
 - The structure shall be assembled in accordance with the Manufacturer's instructions. All plates shall be unloaded and handled with reasonable care. Plates shall not be rolled or dragged over gravel rock and shall be prevented from sinking rock or other hard objects during placement in trench or on bedding.
 - The structure shall be backfilled using clean well graded granular material that meets the requirements for soil classifications A-1, A-2-4, A-2-5 or A-3 modified per AASHTO M-145. See the structural plate backfill group classification table on this sheet. Backfill must be placed symmetrically on each side of the structure in 8 inch loose lifts. Each lift shall be compacted to a minimum of 80 percent density per AASHTO T-180.
 - If temporary construction vehicles are required to cross the structure, it is the Contractor's responsibility to contact the Engineer to determine the amount of additional minimum cover necessary to handle the specific loading condition.